

Pioneer

Operation Manual

CD RDS RECEIVER

FH-X700BT

Made for



iPod



iPhone



English

Before you start

Thank you for purchasing this PIONEER product

To ensure proper use, please read through this manual before using this product. It is especially important that you read and observe

WARNINGS and **CAUTIONS** in this manual. Please keep the manual in a safe and accessible place for future reference.



If you want to dispose this product, do not mix it with general household waste. There is a separate collection system for used electronic products in accordance with legislation that requires proper treatment, recovery and recycling.

Private households in the member states of the EU, in Switzerland and Norway may return their used electronic products free of charge to designated collection facilities or to a retailer (if you purchase a similar new one).

For countries not mentioned above, please contact your local authorities for the correct method of disposal.

By doing so you will ensure that your disposed product undergoes the necessary treatment, recovery and recycling and thus prevent potential negative effects on the environment and human health. 

About this unit

The tuner frequencies on this unit are allocated for use in Western Europe, Asia, the Middle East, Africa and Oceania. Use in other areas may result in poor reception. The RDS (radio data system) function only operates in areas with broadcasting RDS signals for FM stations.

CAUTION

This product is a class 1 laser product classified under the Safety of laser products, IEC 60825-1:2007.

CLASS 1 LASER PRODUCT

CAUTION

- Do not allow this unit to come into contact with liquids. Electrical shock could result. Also, damage to this unit, smoke, and overheating could result from contact with liquids.
- The Pioneer CarStereo-Pass is for use only in Germany.
- Always keep the volume low enough to hear outside sounds.
- Avoid exposure to moisture.
- If the battery is disconnected or discharged, any preset memory will be erased.

Note

Function setting operations are completed even if the menu is canceled before the operations are confirmed. 

About this manual

- In the following instructions, USB memories and USB audio players are collectively referred to as "USB storage device".
- In this manual, iPod and iPhone will be referred to as "iPod". 

In case of trouble

Should this unit fail to operate properly, please contact your dealer or nearest authorized PIONEER Service Station. 

Operating this unit

Head unit

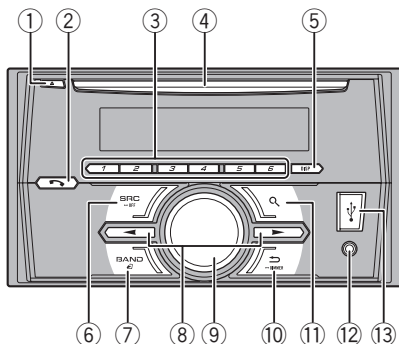

Part	Part
① ▲ (eject)	⑧ ◀▶
② 📞 (phone)	⑨ MULTI-CONTROL (M.C.)
③ 1/∧ to 6/↻	⑩ ◀ (back)/DIMMER (dimmer)
④ Disc loading slot	⑪ 🔍 (list)
⑤ DISP	AUX input jack (3.5 mm stereo jack)
⑥ SRC/OFF	⑬ USB port
⑦ BAND/ (iPod control)	

⚠ CAUTION

- Use an optional Pioneer USB cable (CD-U50E) to connect the USB storage device as any device connected directly to the unit will protrude out from the unit, which could be dangerous.
- Do not use unauthorized products. ▣

Optional remote control

The remote control CD-SR110 is sold separately.



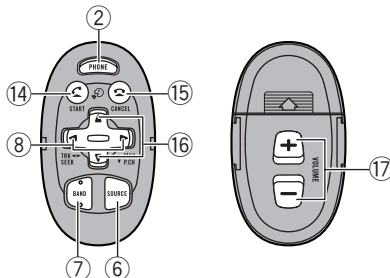



Remote controller buttons marked with the same numbers as on the unit operate in the same way as the corresponding unit button regardless of button name.

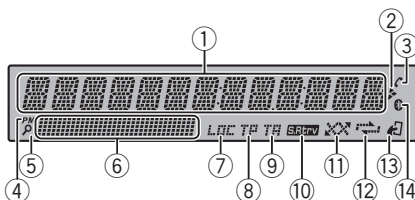

Part	Operation
⑭ 📞	Press to start talking on the phone while operating a phone.
⑮ 📞	Press to end a call, reject an incoming call, or reject a call waiting while on another call.
⑯ ▲/▼	Press to recall preset stations. Press to select the next/previous folder.
⑰ VOLUME	Press to increase or decrease volume.

Display indication



Indicator	State
①	Main information section <ul style="list-style-type: none"> • Tuner: band and frequency • RDS: program service name, PTY information and other literal information • CD player, USB storage device and iPod: elapsed playback time and text information
②	 Appears when a lower tier of folder or menu exists.
③	 (auto answer) Shows when the automatic answering function is on.
④	PM Shows when 12H is selected under 12H/24H and CLOCK is selected under INFO DISPLAY .
⑤	 (list) The list function is being operated.
⑥	Sub information section Sub information is displayed.
⑦	LOC Local seek tuning is on.
⑧	TP (traffic program identification) A TP station is tuned in.
⑨	TA (traffic announcements) TA function is on.
⑩	S.Rtrv (sound retriever) The sound retriever function is on.
⑪	 (random/shuffle) Random play is on. The iPod source is selected and the shuffle or shuffle all function is on.
⑫	 (repeat) Track or folder repeat is on.
⑬	 (iPod control) This unit's iPod function is operated from your iPod.
⑭	 (Bluetooth indicator) Connected to a Bluetooth device. The line is on hold.



Set up menu

When you turn the ignition switch to ON after installation, set up menu appears on the display.

You can set up the menu options below.

1 After installation of this unit, turn the ignition switch to ON.

SET UP appears.

2 Turn M.C. to switch to YES.

- If you do not operate for 30 seconds, the set up menu will not be displayed.

- If you prefer not to set up at this time, turn **M.C.** to switch to **NO**. Press to select.

If you select **NO**, you cannot set up in the set up menu.

3 Press M.C. to select.

4 Perform the following procedures to set the menu.

To proceed to the next menu option, you need to confirm your selection.

LANGUAGE (multi-language)

This unit can display the text information from a compressed audio file even for information embedded in English or Russian.

- If the embedded language and the selected language setting are not the same, text information may not display properly.
- Some characters may not be displayed properly.

① Turn **M.C.** to select the desired setting.

ENG (English)—**PYC** (Russian)

② Press **M.C.** to confirm the selection.

CLOCK SET (setting the clock)

① Turn **M.C.** to adjust hour.

② Press **M.C.** to select minute.

③ Turn **M.C.** to adjust minute.

④ Press **M.C.** to confirm the selection.

Operating this unit

FM STEP (FM tuning step)

Normally, the FM tuning step employed by seek tuning is 50 kHz. When AF or TA is on, the tuning step automatically changes to 100 kHz. It may be preferable to set the tuning step to 50 kHz when AF is on.

- The tuning step remains at 50 kHz during manual tuning.
- 1 Turn **M.C.** to select the FM tuning step.
50 (50 kHz)—**100** (100 kHz)
 - 2 Press **M.C.** to confirm the selection.
QUIT appears.

5 To finish your settings, turn M.C. to select YES.

- If you prefer to change your setting again, turn **M.C.** to switch to **NO**. Press to select.

6 Press M.C. to select.

Notes

- You can set up the menu options from the system menu. For details about the settings, refer to *System menu* on page 17.
- You can cancel set up menu by pressing **SRC/OFF**.

Basic operations

Turning the unit on 1 Press SRC/OFF to turn the unit on.
Turning the unit off 1 Press and hold SRC/OFF until the unit turns off.
Selecting a source 1 Press SRC/OFF to cycle between: TUNER (tuner)— CD (CD player)— USB (USB)/ iPod (iPod)— AUX (AUX)— BT AUDIO (Bluetooth audio)
Adjusting the volume 1 Turn M.C. to adjust the volume.



CAUTION

For safety reasons, park your vehicle when removing the front panel.

Note

When this unit's blue/white lead is connected to the vehicle's auto-antenna relay control terminal, the vehicle's antenna extends when this unit's source is turned on. To retract the antenna, turn the source off.

Frequently used menu operations

Returning to the previous display
Returning to the previous list (the folder one level higher)

- 1 Press **↵**/**DIMMER**.

Returning to the ordinary display
Canceling the main menu

- 1 Press **BAND**/**↵**.

Returning to the ordinary display from the list

- 1 Press **BAND**/**↵**.



Tuner

Basic operations

Selecting a band

- 1 Press **BAND**/**↵** until the desired band (**FM1**, **FM2**, **FM3** for FM or **MW/LW**) is displayed.

Switching preset stations

- 1 Press **◀** or **▶**.
 - Select **PCH** (preset channel) under **SEEK** to use this function. For details about the settings, refer to **SEEK** (*left/right key setting*) on page 7.

Manual tuning (step by step)

- 1 Press **◀** or **▶**.
 - Select **MAN** (manual tuning) under **SEEK** to use this function. For details about the settings, refer to **SEEK** (*left/right key setting*) on page 7.

Seeking

- 1 Press and hold **◀** or **▶**, and then release.
 - You can cancel seek tuning by briefly pressing **◀** or **▶**.
 - While pressing and holding **◀** or **▶**, you can skip stations. Seek tuning starts as soon as you release **◀** or **▶**.

Operating this unit

Note

This unit's AF (alternative frequencies search) function can be turned on and off. AF should be off for normal tuning operation (refer to **AF** (*alternative frequencies search*) on the next page).

Storing and recalling stations for each band

Using preset tuning buttons

1 When you find a station that you want to store in memory, press one of the preset tuning buttons (1/∧ to 6/↔) and hold until the preset number stops flashing.

2 Press one of the preset tuning buttons (1/∧ to 6/↔) to select the desired station.

Switching the display

Selecting the desired text information

- 1 Press **DISP** to cycle between the following:
- **FREQUENCY** (program service name or frequency)
 - **BRDCST INFO** (program service name/PTY information)
 - **CLOCK** (source name and clock)

Notes

- If the program service name cannot be acquired in **FREQUENCY**, the broadcast frequency is displayed instead. If the program service name is detected, the program service name will be displayed.
- **BRDCST INFO** text information will change automatically.
- Depending on the band, text information can be changed.
- Text information items that can be changed depend on the area.

Using PTY functions

You can tune in to a station using PTY (program type) information.

Searching for an RDS station by PTY information
You can search for general types of broadcasting programs, such as those listed in the following section. Refer to this page.

- 1 Press **Q** (list).
- 2 Turn **M.C.** to select a program type.
NEWS/INFO—POPULAR—CLASSICS—OTHERS
- 3 Press **M.C.** to begin the search.
The unit searches for a station broadcasting that type of program. When a station is found, its program service name is displayed.
 - To cancel the search, press **M.C.** again.
 - The program of some stations may differ from that indicated by the transmitted PTY.
 - If no station is broadcasting the type of program you searched for, **NOT FOUND** is displayed for about two seconds and then the tuner returns to the original station.

PTY list

NEWS/INFO (news and information)

NEWS (News), **AFFAIRS** (Current affairs), **INFO** (Information), **SPORT** (Sports), **WEATHER** (Weather), **FINANCE** (Finance)

POPULAR (popular)

POP MUS (Popular music), **ROCK MUS** (Rock music), **EASY MUS** (Easy listening), **OTH MUS** (Other music), **JAZZ** (Jazz), **COUNTRY** (Country music), **NAT MUS** (National music), **OLDIES** (Oldies music), **FOLK MUS** (Folk music)

CLASSICS (classics)

L. CLASS (Light classical), **CLASSIC** (Classical)

OTHERS (others)

EDUCATE (Education), **DRAMA** (Drama), **CULTURE** (Culture), **SCIENCE** (Science), **VARIED** (Varied), **CHILDREN** (Children's), **SOCIAL** (Social affairs), **RELIGION** (Religion), **PHONE IN** (Phone in), **TOURING** (Travel), **LEISURE** (Leisure), **DOCUMENT** (Documentaries)

Function settings

- 1 Press **M.C.** to display the main menu.
- 2 Turn **M.C.** to change the menu option and press to select **FUNCTION**.

Operating this unit

3 Turn M.C. to select the function.

Once selected, the following functions can be adjusted.

- If MW/LW band is selected, only **BSM**, **LOCAL** and **SEEK** are available.

BSM (best stations memory)

BSM (best stations memory) automatically stores the six strongest stations in the order of their signal strength.

- 1 Press **M.C.** to turn BSM on.
To cancel, press **M.C.** again.

REGION (regional)

When AF is used, the regional function limits the selection of stations to those broadcasting regional programs.

- 1 Press **M.C.** to turn the regional function on or off.

LOCAL (local seek tuning)

Local seek tuning lets you tune in to only those radio stations with sufficiently strong signals for good reception.

- 1 Press **M.C.** to select the desired setting.

FM: **OFF—LV1—LV2—LV3—LV4**

MW/LW: **OFF—LV1—LV2**

The highest level setting allows reception of only the strongest stations, while lower levels allow the reception of weaker stations.

TA (traffic announcement standby)

- 1 Press **M.C.** to turn traffic announcement standby on or off.

AF (alternative frequencies search)

- 1 Press **M.C.** to turn AF on or off.

NEWS (news program interruption)

- 1 Press **M.C.** to turn the NEWS function on or off.

SEEK (left/right key setting)

You can assign a function to the left and right keys of the unit.

Select **MAN** (manual tuning) to tune up or down manually or select **PCH** (preset channel) to switch between preset channels.

- 1 Press **M.C.** to select **MAN** or **PCH**.

CD/CD-R/CD-RW and USB storage devices

Basic operations

Playing a CD/CD-R/CD-RW

- 1 Insert the disc into the disc loading slot with the label side up.

Ejecting a CD/CD-R/CD-RW

- 1 Press **▲**.

Playing songs on a USB storage device

- 1 Open the USB port cover.
- 2 Plug in the USB storage device using a USB cable.
Playback is performed automatically.

Stopping playback of files on a USB storage device

- 1 You may disconnect the USB storage device at any time.
The unit stops playback.

Selecting a folder

- 1 Press **1/▲** or **2/▼**.

Selecting a track

- 1 Press **◀** or **▶**.

Fast forwarding or reversing

- 1 Press and hold **◀** or **▶**.
 - When playing compressed audio, there is no sound during fast forward or reverse.

Returning to root folder

- 1 Press and hold **BAND/↵**.

Switching between compressed audio and CD-DA

- 1 Press **BAND/↵**.

Switching between playback memory devices

You can switch between playback memory devices on USB storage devices with more than one Mass Storage Device-compatible memory device.

- 1 Press **BAND/↵**.
 - You can switch between up to 32 different memory devices.

Note

Disconnect USB storage devices from the unit when not in use.



Operations using the MIXTRAX button

Turning MIXTRAX on or off

You can use this function when **USB** is selected as the source.

1 Press **3/MIX** to turn MIXTRAX on or off.

- For more details about MIXTRAX, refer to *About MIXTRAX* on page 20.
- For more details about MIXTRAX functions, refer to *MIXTRAX menu* on page 20.
- When MIXTRAX is in use, the sound retriever function is disabled.

Switching the display

Selecting the desired text information

1 Press **DISP** to cycle between the following:

CD-DA

- **ELAPSED TIME** (track number and playback time)
- **CLOCK** (source name and clock)
- **SPEANA** (spectrum analyzer)

CD-TEXT

- **TRACK INFO** (track title/track artist/disc title)
- **ELAPSED TIME** (track number and playback time)
- **CLOCK** (source name and clock)
- **SPEANA** (spectrum analyzer)

MP3/WMA/WAV

- **TRACK INFO** (track title/artist name/album title)
- **FILE INFO** (file name/folder name)
- **ELAPSED TIME** (track number and playback time)
- **CLOCK** (source name and clock)
- **SPEANA** (spectrum analyzer)

Notes

- **TRACK INFO** and **FILE INFO** text information will change automatically.
- Depending on the version of iTunes used to write MP3 files to a disc or media file types, incompatible text stored within an audio file may be displayed incorrectly.
- Text information items that can be changed depend on the media.

Selecting and playing files/tracks from the name list

1 Press **Q** to switch to the file/track name list mode.

2 Use **M.C.** to select the desired file name (or folder name).

Selecting a file or folder

1 Turn **M.C.**

Playing

1 When a file or track is selected, press **M.C.**

Viewing a list of the files (or folders) in the selected folder

1 When a folder is selected, press **M.C.**

Playing a song in the selected folder

1 When a folder is selected, press and hold **M.C.**

Operations using special buttons

Selecting a repeat play range

1 Press **6/↔** to cycle between the following:

CD/CD-R/CD-RW

- **ALL** – Repeat all tracks
- **ONE** – Repeat the current track
- **FLD** – Repeat the current folder

USB storage device

- **ALL** – Repeat all files
- **ONE** – Repeat the current file
- **FLD** – Repeat the current folder

Playing tracks in random order

1 Press **5/∞** to turn random play on or off.

Tracks in a selected repeat range are played in random order.

- To change songs during random play, press **▶** to switch to the next track. Pressing **◀** restarts playback of the current track from the beginning of the song.

Pausing playback

1 Press **4/PAUSE** to pause or resume.

Function settings

1 Press **M.C.** to display the main menu.

Operating this unit

2 Turn M.C. to change the menu option and press to select FUNCTION.

Once selected, the function below can be adjusted.

- **S.RTRV** is not available when MIXTRAX is turned on.

S.RTRV (sound retriever)

Automatically enhances compressed audio and restores rich sound.

- 1 Press **M.C.** to select the desired setting.
 - 1—**2**—**OFF** (off)
- 1** is effective for low compression rates, and **2** is effective for high compression rates.



iPod

Basic operations

Playing songs on an iPod

- 1 Open the USB port cover.
- 2 Connect an iPod to the USB cable using an iPod Dock Connector.
Playback is performed automatically.

Selecting a song (chapter)

- 1 Press ◀ or ▶.

Selecting an album

- 1 Press 1/∧ or 2/∨.

Fast forwarding or reversing

- 1 Press and hold ◀ or ▶.

Notes

- The iPod cannot be turned on or off when the control mode is set to **CONTROL AUDIO**.
- Disconnect headphones from the iPod before connecting it to this unit.
- The iPod will turn off about two minutes after the ignition switch is set to OFF.

Operations using the MIXTRAX button

Turning MIXTRAX on or off

- 1 Press **3/MIX** to turn MIXTRAX on or off.
 - For more details about MIXTRAX, refer to *About MIXTRAX* on page 20.
 - For more details about MIXTRAX functions, refer to *MIXTRAX menu* on page 20.

Switching the display

Selecting the desired text information

- 1 Press **DISP** to cycle between the following:
 - CONTROL AUDIO/CONTROL iPod**
 - **TRACK INFO** (track title/artist name/album title)
 - **ELAPSED TIME** (track number and playback time)
 - **CLOCK** (source name and clock)
 - **SPEANA** (spectrum analyzer)
 - CONTROL APP**
 - **CONTROL APP (APP MODE)** is displayed
 - **CLOCK** (source name and clock)
 - **SPEANA** (spectrum analyzer)

Note

TRACK INFO text information will change automatically.

Browsing for a song

1 Press 🔍 **to switch to the top menu of list search.**

2 Use M.C. to select a category/song.

Changing the name of the song or category

- 1 Turn **M.C.**
Playlists—artists—albums—songs—podcasts—genres—composers—audiobooks

Playing

- 1 When a song is selected, press **M.C.**

Viewing a list of songs in the selected category

- 1 When a category is selected, press **M.C.**

Operating this unit

Playing a song in the selected category

- 1 When a category is selected, press and hold **M.C.**

Searching the list by alphabet

- 1 When a list for the selected category is displayed, press **Q** to switch to alphabet search mode.
 - You also can switch to alphabet search mode by turning **M.C.** twice.
- 2 Turn **M.C.** to select a letter.
- 3 Press **M.C.** to display the alphabetical list.
 - To cancel searching, press **➡/DIMMER**.

Notes

- You can play playlists created with the PC application (MusicSphere). The application will be available on our website.
- Playlists that you created with the PC application (MusicSphere) are displayed in abbreviated form.

Operations using special buttons

Selecting a repeat play range

- 1 Press **6/↔** to cycle between the following:
 - **ONE** – Repeat the current song
 - **ALL** – Repeat all songs in the selected list
- When the control mode is set to **CONTROL iPod/CONTROL APP** the repeat play range will be same as what is set for the connected iPod.

Selecting a random play range (shuffle)

- 1 Press **5/🔀** to cycle between the following:
 - **SNG** – Play back songs in the selected list in random order.
 - **ALB** – Play back songs from a randomly selected album in order.
 - **OFF** – Not play back in random order.

Playing all songs in random order (shuffle all)

- 1 Press and hold **5/🔀** to turn shuffle all on.
 - To turn off shuffle all, select **OFF** in shuffle. For details, refer to *Selecting a random play range (shuffle)* on this page.

Pausing playback

- 1 Press **4/PAUSE** to pause or resume.

Playing songs related to the currently playing song

You can play songs from the following lists.

- Album list of the currently playing artist
- Song list of the currently playing album
- Album list of the currently playing genre

1 Press and hold **Q** to switch to link play mode.

2 Turn **M.C.** to change the mode; press to select.

- **ARTIST** – Plays an album of the artist currently being played.
- **ALBUM** – Plays a song from the album currently being played.
- **GENRE** – Plays an album from the genre currently being played.

The selected song/album will be played after the currently playing song.

Notes

- The selected song/album may be canceled if you operate functions other than link search (e.g. fast forward and reverse).
- Depending on the song selected to play, the end of the currently playing song and the beginning of the selected song/album may be cut off.

Operating this unit's iPod function from your iPod

This unit's iPod function can be operated from a connected iPod.

If you switch to APP Mode, you can have the sound from your iPod applications be output from your car's speakers.

CONTROL iPod is not compatible with the following iPod models.

- iPod nano 1st generation
- iPod with video

CONTROL APP is compatible with the following iPod models.

- iPod touch 4th generation
- iPod touch 3rd generation
- iPod touch 2nd generation

Operating this unit

- iPod touch 1st generation
 - iPhone 4S
 - iPhone 4
 - iPhone 3GS
 - iPhone 3G
 - iPhone
- **Press BAND/ to switch the control mode.**

- **CONTROL iPod** – This unit's iPod function can be operated from the connected iPod.
- **CONTROL APP** – This unit's iPod function can be operated from the connected iPod. The unit will play back the sound from your iPod applications.
- **CONTROL AUDIO** – This unit's iPod function can be operated from this unit.

Notes

- Switching the control mode to **CONTROL iPod/CONTROL APP** pauses song playback. Operate the iPod to resume playback.
- The following operations are still accessible from the unit even if the control mode is set to **CONTROL iPod/CONTROL APP**.
 - Pausing
 - Fast forward/reverse
 - Selecting a song (chapter)
- The volume can only be adjusted from this unit.

Function settings

1 Press M.C. to display the main menu.

2 Turn M.C. to change the menu option and press to select FUNCTION.

3 Turn M.C. to select the function.

Once selected, the following functions can be adjusted.

- **AUDIO BOOK** is not available when **CONTROL iPod/CONTROL APP** is selected in the control mode. For details, refer to *Operating this unit's iPod function from your iPod* on the previous page.

AUDIO BOOK (audiobook speed)

- 1 Press **M.C.** to display the setting mode.
- 2 Turn **M.C.** to select your favorite setting.
 - **FASTER** – Playback at a speed faster than normal
 - **NORMAL** – Playback at normal speed
 - **SLOWER** – Playback at a speed slower than normal

S.RTRV (sound retriever)

Automatically enhances compressed audio and restores rich sound.

- 1 Press **M.C.** to select the desired setting.
 - 1—2—OFF** (off)
 - 1** is effective for low compression rates, and **2** is effective for high compression rates.



Using Bluetooth wireless technology

Using Bluetooth telephone

Important

- Since this unit is on standby to connect with your cellular phone via Bluetooth wireless technology, using it without the engine running can drain the battery power.
- Operations may vary depending on the kind of cellular phone.
- Advanced operations that require attention such as dialing numbers on the monitor, using the phone book, etc., are prohibited while driving. Park your vehicle in a safe place when using these advanced operations.
- Be sure to park your vehicle in a safe place and apply the parking brake when performing this operation.





Setting up for hands-free phoning

Before you can use the hands-free phoning function you must set up the unit for use with your cellular phone.

Operating this unit

- | |
|---|
| <p>1 Connection
Operate the Bluetooth telephone connection menu. Refer to <i>Connection menu operation</i> on the next page.</p> <p>2 Function settings
Operate the Bluetooth telephone function menu. Refer to <i>Phone menu operation</i> on page 14.</p> |
|---|

Basic operations

<p>Making a phone call 1 Refer to <i>Phone menu operation</i> on page 14.</p>
<p>Answering an incoming call 1 When a call is received, press .</p>
<p>Ending a call 1 Press .</p>
<p>Rejecting an incoming call 1 When a call is received, press and hold .</p>
<p>Answering a call waiting 1 When a call is received, press .</p>
<p>Switching between callers on hold 1 Press M.C.</p>
<p>Canceling call waiting 1 Press and hold .</p>
<p>Adjusting the other party's listening volume 1 Press ◀ or ▶ while talking on the phone. • When private mode is on, this function is not available.</p>
<p>Turning private mode on or off 1 Press BAND/ while talking on the phone.</p>

Notes

- If private mode is selected on the cellular phone, hands-free phoning may not be available.
- The estimated call time appears in the display (this may differ slightly from the actual call time).

Storing and recalling phone numbers

1 If you find a phone number that you want to store to memory, press and hold down one of the preset tuning buttons (1/∧ to 6/⇌) to store it to the relevant preset tuning button.

The functions below can be used to store phone numbers to the memory. For details, refer to *Phone menu operation* on page 14.

- **MISSED** (missed call history)
- **DIALLED** (dialed call history)
- **RECEIVED** (received call history)
- **PHONE BOOK** (phone book)

2 Press one of the preset tuning buttons (1/∧ to 6/⇌) to recall the desired phone number.

3 Press M.C. to make a call.

Switching the display

- | |
|---|
| <p>Selecting the desired text information
You can change the display during a call.
1 Press DISP to cycle between the following:</p> <ul style="list-style-type: none"> • Call time • Name of other party • Number of other party |
|---|

Using voice recognition

This feature can be used on an iPod equipped with voice recognition that is connected by Bluetooth with the source set to **iPod** or **BT AUDIO**.

● **Press and hold M.C. to switch to voice recognition mode.**

The commands available with this unit are listed below.

- Song playback
- Making a phone call

Note

For details on voice recognition features, check the manual for the iPod you are using.

Operating this unit

Connection menu operation

Important

- Be sure to park your vehicle in a safe place and apply the parking brake when performing this operation.
- Connected devices may not operate properly if more than one Bluetooth device is connected at a time (e.g. a phone and a separate audio player are connected simultaneously).

1 Press and hold to display the connection menu.

- You cannot operate this step during a call.

2 Turn **M.C.** to select the function.

Once selected, the following functions can be adjusted.

DEVICELIST (connecting or disconnecting a device from the device list)

- When no device is selected in the device list, this function is not available.
- 1 Press **M.C.** to display the setting mode.
 - 2 Turn **M.C.** to select the name of a device you want to connect/disconnect.
 - Press and hold **M.C.** to switch the Bluetooth device address and device name.
 - 3 Press **M.C.** to connect/disconnect the selected device.

If the connection is established, * is indicated on the device name.

DEL DEVICE (deleting a device from the device list)

- When no device is selected in the device list, this function is not available.
- 1 Press **M.C.** to display the setting mode.
 - 2 Turn **M.C.** to select the name of a device you want to delete.
 - Press and hold **M.C.** to switch the Bluetooth device address and device name.
 - 3 Press **M.C.** to display **DELETE YES**.
 - 4 Press **M.C.** to delete a device information from the device list.
 - While this function is in use, do not turn off the engine.

ADD DEVICE (connecting a new device)

- 1 Press **M.C.** to start searching.
 - To cancel, press **M.C.** while searching.
 - If this unit fails to find any available cellular phones, **NOT FOUND** is displayed.
- 2 Turn **M.C.** to select a device from the device list.
 - If the desired device is not displayed, select **RE-SEARCH**.
 - Press and hold **M.C.** to switch the Bluetooth device address and device name.
- 3 Press **M.C.** to connect the selected device.
 - To complete the connection, check the device name (**Pioneer BT Unit**) and enter the PIN code on your device.
 - PIN code is set to **0000** as the default. You can change this code.
 - 6-digit number appears on the display of this unit. Once the connection is established, this number disappears.
 - If you are unable to complete the connection using this unit, use the device to connect to the unit.
 - If three devices are already paired, **DEVICE-FULL** is displayed and it is not possible to perform this operation. In this case, delete a paired device first.

A. CONN (connecting to a Bluetooth device automatically)

- 1 Press **M.C.** to turn automatic connection on or off.

VISIBLE (setting the visibility of this unit)

To check the availability of this unit from other devices, Bluetooth visibility of this unit can be turned on.

- 1 Press **M.C.** to turn the visibility of this unit on or off.

PIN CODE (PIN code input)

To connect your device to this unit via Bluetooth wireless technology, you need to enter a PIN code on your device to verify the connection. The default code is **0000**, but you can change it with this function.

- 1 Press **M.C.** to display the setting mode.
- 2 Turn **M.C.** to select a number.
- 3 Press **M.C.** to move the cursor to the next position.
- 4 After inputting PIN code, press and hold **M.C.**
 - After inputting, pressing **M.C.** returns you to the PIN code input display, and you can change the PIN code.

Operating this unit

DEV. INFO (Bluetooth device address display)

- 1 Press **M.C.** to display the setting mode.
- 2 Turn **M.C.** to display the device information.
Device name—Bluetooth device address

Phone menu operation

Important

Be sure to park your vehicle in a safe place and apply the parking brake when performing this operation.

1 Press to display the phone menu.

▪ When **PW SAVE** is on, you cannot display the phone menu. For details about the settings, refer to **PW SAVE** (*power saving*) on page 18.

2 Turn **M.C.** to select the function.

Once selected, the following functions can be adjusted.

MISSED (missed call history)
DIALLED (dialed call history)
RECEIVED (received call history)

- 1 Press **M.C.** to display the phone number list.
- 2 Turn **M.C.** to select a name or phone number.
- 3 Press **M.C.** to make a call.

PHONE BOOK (phone book)

- The phone book in your cellular phone will be transferred automatically when the phone is connected to this unit.
- Depending on the cellular phone, the phone book may not be transferred automatically. In this case, operate your cellular phone to transfer the phone book. The visibility of this unit should be on. Refer to **VISIBLE** (*setting the visibility of this unit*) on the previous page.

- 1 Press **M.C.** to display **SEARCH** (alphabetical list).
- 2 Turn **M.C.** to select the first letter of the name you are looking for.
 - Press and hold **M.C.** to select the desired character type.
 - TOP** (alphabet)–**OAA** (Greek alphabet)–**BCE** (Cyrillic alphabet)
- 3 Press **M.C.** to display a registered name list.
- 4 Turn **M.C.** to select the name you are looking for.
- 5 Press **M.C.** to display the phone number list.
- 6 Turn **M.C.** to select a phone number you want to call.
- 7 Press **M.C.** to make a call.

PRESET 1-6 (preset phone numbers)

- 1 Press **M.C.** to display the setting mode.
- 2 Turn **M.C.** to select the desired preset number.
- 3 Press **M.C.** to make a call.
 - You can also use the preset number buttons **1/▲** to **6/▶** to recall a preset phone number. For more details about storing phone numbers, refer to *Storing and recalling phone numbers* on page 12.

PHONE FUNC (phone function)

You can set **A. ANSR**, **R.TONE** and **PB INVT** from this menu. For details, refer to *Function and operation* on this page.

Function and operation

1 Display PHONE FUNC.

Refer to **PHONE FUNC** (*phone function*) on this page.

2 Press **M.C.** to display the function menu.

3 Turn **M.C.** to select the function.

Once selected, the following functions can be adjusted.

Operating this unit

A. ANSR (automatic answering)

- 1 Press **M.C.** to turn automatic answering on or off.

R.TONE (ring tone select)

- 1 Press **M.C.** to turn the ring tone on or off.

PB INVT (phone book name view)

- 1 Press **M.C.** to invert the order of names in the phone book.

Bluetooth Audio

Important

- Depending on the Bluetooth audio player connected to this unit, the available operations will be limited to the following two levels:
 - A2DP profile (Advanced Audio Distribution Profile): You can only playback songs on your audio player.
You cannot use the A2DP connection when **iPod** is selected as a source.
 - AVRCP profile (Audio/Video Remote Control Profile): You can perform playback, pause playback, select songs, etc.
- Since there are a number of Bluetooth audio players available on the market, available operations will vary extensively. When operating your player with this unit, refer to the instruction manual that came with your Bluetooth audio player as well as this manual.
- As the signal from your cellular phone may cause noise, avoid using it when you are listening to songs on your Bluetooth audio player.
- When a call is in progress on the cellular phone connected to this unit via Bluetooth wireless technology, the sound of the Bluetooth audio player connected to this unit is muted.
- When the Bluetooth audio player is in use, you cannot connect to a Bluetooth telephone automatically.
- Playback continues even if you switch from your Bluetooth audio player to another source while listening to a song.

- Depending on the type of Bluetooth audio player you have connected to this unit, operation and information display may not be available for some functions.

Setting up for Bluetooth audio

Before you can use the Bluetooth audio function you must set up the unit for use with your Bluetooth audio player. This entails establishing a Bluetooth wireless connection between this unit and your Bluetooth audio player, and pairing your Bluetooth audio player with this unit.

- 1 Connection
Operate the Bluetooth telephone connection menu. Refer to *Connection menu operation* on page 13.

Basic operations

Fast forwarding or reversing

- 1 Press and hold ◀ or ▶.

Selecting a track

- 1 Press ◀ or ▶.

Starting playback

- 1 Press **BAND**/**⏪**.

Switching the display

Selecting the desired text information

- 1 Press **DISP** to cycle between the following:
- DEVICE INFO** (device name)
 - TRACK INFO** (track title/artist name/album title)
 - ELAPSED TIME** (track number and playback time)
 - CLOCK** (source name and clock)
 - SPEANA** (spectrum analyzer)

Notes

- TRACK INFO** text information will change automatically.
- Depending on the device, text information can be changed.

Operations using special buttons

Selecting a repeat play range

- 1 Press **6**/ to select a repeat play range from one or all.
 - This function may not be available depending on the type of Bluetooth audio player connected.
 - The repeat play range varies depending on the Bluetooth audio player in use.

Playing tracks in random order

- 1 Press **5**/ to turn random play on or off.
 - The random play range varies depending on the Bluetooth audio player in use.

Pausing playback

- 1 Press **4**/**PAUSE** to pause or resume.

Function settings

1 Press M.C. to display the main menu.

2 Turn M.C. to change the menu option and press to select FUNCTION.

3 Turn M.C. to select the function.

Once selected, the following functions can be adjusted.

PLAY (play)

- 1 Press **M.C.** to start playback.

STOP (stop)

- 1 Press **M.C.** to stop the playback.

S.RTRV (sound retriever)

Automatically enhances compressed audio and restores rich sound.

- 1 Press **M.C.** to select the desired setting.
 - 1—2—OFF (off)
 - 1 is effective for low compression rates, and 2 is effective for high compression rates.



2 Turn M.C. to change the menu option and press to select AUDIO.

3 Turn M.C. to select the audio function.

Once selected, the following audio functions can be adjusted.

- **FADER** is not available when **SUB.W/SUB.W** is selected in **SP-P/O MODE**. For details, refer to **SP-P/O MODE** (rear output and preout setting) on page 21.
- **SUB.W, SUB.W CTRL** and **HPF SETTING** are not available when **REAR/REAR** is selected in **SP-P/O MODE**. For details, refer to **SP-P/O MODE** (rear output and preout setting) on page 21.
- **SUB.W CTRL** and **HPF SETTING** are not available when **SUB.W** is selected in **OFF**. For details, refer to **SUB.W** (subwoofer on/off setting) on the next page.

FADER (fader adjustment)

- 1 Press **M.C.** to display the setting mode.
- 2 Turn **M.C.** to adjust the front/rear speaker balance.

BALANCE (balance adjustment)

- 1 Press **M.C.** to display the setting mode.
- 2 Turn **M.C.** to adjust the left/right speaker balance.

EQ SETTING (equalizer recall)

Audio adjustments

1 Press M.C. to display the main menu.

Operating this unit

- 1 Press **M.C.** to display the setting mode.
- 2 Turn **M.C.** to select the equalizer.
POWERFUL—NATURAL—VOCAL—CUSTOM1—CUSTOM2—FLAT—SUPER BASS
 The equalizer band and equalizer level can be customized when **CUSTOM1** or **CUSTOM2** is selected.
 If selecting **CUSTOM1** or **CUSTOM2**, complete the procedures outlined below. If selecting other options, press **M.C.** to return to the previous display.
 - **CUSTOM1** can be set separately for each source. However, **USB** and **iPod** are all set to the same setting automatically.
 - **CUSTOM2** is a shared setting used in common for all sources.
- 3 Press **M.C.** to display the setting mode.
- 4 Press **M.C.** to cycle between the following:
 Equalizer band—Equalizer level
- 5 Turn **M.C.** to select the desired setting.
 Equalizer band: **80HZ—250HZ—800HZ—2.5KHZ—8KHZ**
 Equalizer level: **+6** to **-6**

LOUDNESS (loudness)

Loudness compensates for deficiencies in the low-frequency and high-frequency ranges at low volume.

- 1 Press **M.C.** to select the desired setting.
OFF (off)—**LOW** (low)—**MID** (mid)—**HI** (high)

SUB.W (subwoofer on/off setting)

This unit is equipped with a subwoofer output which can be turned on or off.

- 1 Press **M.C.** to select the desired setting.
NOR (normal phase)—**REV** (reverse phase)—**OFF** (subwoofer off)

SUB.W CTRL (subwoofer adjustment)

Only frequencies lower than those in the selected range are outputted from the subwoofer.

- 1 Press **M.C.** to display the setting mode.
- 2 Press **M.C.** to cycle between the following:
 Cut-off frequency—Output level—Slope level
 Rates that can be adjusted will flash.
- 3 Turn **M.C.** to select the desired setting.
 Cut-off frequency: **50HZ—63HZ—80HZ—100HZ—125HZ—160HZ—200HZ**
 Output level: **-24** to **+6**
 Slope level: **-6—-12**

BASS BOOST (bass boost)

- 1 Press **M.C.** to display the setting mode.
- 2 Turn **M.C.** to select a desired level.
0 to **+6** is displayed as the level is increased or decreased.

HPF SETTING (high pass filter adjustment)

When you do not want low sounds from the subwoofer output frequency range to play from the front or rear speakers, turn on the HPF (high pass filter). Only frequencies higher than those in the selected range are output from the front or rear speakers.

- 1 Press **M.C.** to display the setting mode.
- 2 Press **M.C.** to cycle between the following:
 Cut-off frequency—Slope level
- 3 Turn **M.C.** to select the desired setting.
 Cut-off frequency: **OFF—50HZ—63HZ—80HZ—100HZ—125HZ—160HZ—200HZ**
 Slope level: **-6—-12**

SLA (source level adjustment)

SLA (Source level adjustment) lets you adjust the volume level of each source to prevent radical changes in volume when switching between sources.

- Settings are based on the FM volume level, which remains unchanged.
- The MW/LW volume level can also be adjusted with this function.
- When selecting FM as the source, you cannot switch to **SLA**.
- **USB** and **iPod** are all set to the same setting automatically.

- 1 Press **M.C.** to display the setting mode.
- 2 Turn **M.C.** to adjust the source volume.
 Adjustment range: **+4** to **-4**



System menu

Important

PW SAVE (power saving) is canceled if the vehicle battery is disconnected and will need to be turned back on once the battery is reconnected. When **PW SAVE** (power saving) is off, depending on connection methods, the unit may continue to draw power from the battery if your vehicle's ignition doesn't have an **ACC** (accessory) position.

- 1 Press **M.C.** to display the main menu.

Operating this unit

2 Turn **M.C.** to change the menu option and press to select **SYSTEM**.

3 Turn **M.C.** to select the system menu function.

Once selected, the following system menu functions can be adjusted.

LANGUAGE (multi-language)

This unit can display the text information from a compressed audio file even for information embedded in English or Russian.

- If the embedded language and the selected language setting are not the same, text information may not display properly.
- Some characters may not be displayed properly.

1 Press **M.C.** to select the desired setting.
ENG (English)—**PYC** (Russian)

CLOCK SET (setting the clock)

- 1 Press **M.C.** to display the setting mode.
2 Press **M.C.** to select the segment of the clock display you wish to set.
Hour—Minute
3 Turn **M.C.** to adjust the clock.

12H/24H (time notation)

1 Press **M.C.** to select the desired setting.
12H (12-hour clock)—**24H** (24-hour clock)

INFO DISPLAY (sub information)

The type of text information displayed in the sub information section can be toggled.

- 1 Press **M.C.** to display the setting mode.
2 Turn **M.C.** to select the desired setting.
SPEANA—LEVEL METER—SOURCE—CLOCK—OFF
- The signal bar indicator displays for **SPEANA** or **LEVEL METER** when the source is set to **TUNER**.

AUTO PI (auto PI seek)

The unit can automatically search for a different station with the same programming, even during preset recall.

1 Press **M.C.** to turn Auto PI seek on or off.

AUX (auxiliary input)

Activate this setting when using an auxiliary device connected to this unit.

1 Press **M.C.** to turn **AUX** on or off.

BT AUDIO (Bluetooth audio activation)

You need to activate the **BT AUDIO** source in order to use a Bluetooth audio player.

1 Press **M.C.** to turn the **BT AUDIO** source on or off.

PW SAVE (power saving)

Switching this function on enables you to reduce the consumption of battery power.

- Turning on the source is the only operation allowed when this function is on.

1 Press **M.C.** to turn the power save on or off.

BT MEM CLEAR (clearing the Bluetooth device data stored on this unit)

Bluetooth device data stored on this unit can be cleared. To protect personal information, we recommend that you clear this data before transferring this unit to other persons. The following types of data on this unit will be cleared in such cases.

- Device list
- PIN code
- Call history
- Phone book
- Preset phone numbers

1 Press **M.C.** to show the confirmation display. **YES** is displayed. Clearing memory is now on standby.

If you do not want to clear the Bluetooth device data stored on this unit, turn **M.C.** to display **CANCEL** and press it again to select.

2 Press **M.C.** to clear the memory. **CLEARED** is displayed and the Bluetooth device data is cleared.

- While this function is in use, do not turn off the engine.

BT VERSION (Bluetooth version display)

You can display the system versions of this unit and of Bluetooth module.

1 Press **M.C.** to display the information.



Selecting the key color

You can select desired colors for the keys of this unit.

1 Press **M.C.** to display the main menu.

2 Turn **M.C.** to display **ILLUMI** and press to select.

Operating this unit

3 Turn M.C. to display KEY COLOUR and press to select.

4 Turn M.C. to select the illumination color.

You can select any one of the options in the following list:

- Preset colors (ranging from **WHITE** to **ROSE**)
- **SCAN** (cycle through all colors)
- Sets of colors (**WARM, AMBIENT, CALM**)
- **CUSTOM** (customized illumination color)

Notes

- When **SCAN** is selected, the system automatically cycles through the preset colors.
- When **WARM** is selected, the system automatically cycles through the warm colors.
- When **AMBIENT** is selected, the system automatically cycles through the ambient colors.
- When **CALM** is selected, the system automatically cycles through the calm colors.
- When **CUSTOM** is selected, the customized color saved is selected. 

Selecting the display color

You can select the desired colors for the display of this unit.

1 Press M.C. to display the main menu.

2 Turn M.C. to display ILLUMI and press to select.

3 Turn M.C. to display DISP COLOUR and press to select.

4 Turn M.C. to select the illumination color.

You can select any one of the options in the following list:

- Preset colors (ranging from **WHITE** to **ROSE**)
- **SCAN** (cycle through all colors)
- Sets of colors (**WARM, AMBIENT, CALM**)
- **CUSTOM** (customized illumination color)

Note

For details about colors on the list, refer to *Selecting the key color* on the previous page. 

Selecting key and display color

You can select the desired colors for the keys and display of this unit.

1 Press M.C. to display the main menu.

2 Turn M.C. to display ILLUMI and press to select.

3 Turn M.C. to display BOTH COLOUR and press to select.

4 Turn M.C. to select the illumination color.

You can select any one of the options in the following list:

- Preset colors (ranging from **WHITE** to **ROSE**)
- **SCAN** (cycle through all colors)

Notes

- Once you select a color in this function, colors on the keys and display of this unit automatically switch to the color you selected.
- For details about colors on the list, refer to *Selecting the key color* on the previous page. 

Selecting the key colors displayed when a call is received

You can select the desired key colors to display when an incoming call is received.

1 Press M.C. to display the main menu.

2 Turn M.C. to display ILLUMI and press to select.

3 Turn M.C. to display PHONE COLOUR and press to select.

Operating this unit

4 Turn M.C. to select the illumination color.

You can select any one of the options in the following list:

- **FLASHING** – The color selected from **KEY COLOUR** flashes.
- **FLASH MODE1** to **FLASH MODE6** – The system automatically cycles through all available key colors for this unit. Select the desired mode.
- **OFF** – No change in key color made when incoming calls are received. 

Switching the dimmer setting



You can adjust the brightness of illumination.

1 Press M.C. to display the main menu.

2 Turn M.C. to display ILLUMI and press to select.

3 Turn M.C. to display DIMMER and press to select the desired setting.

OFF (off)—**ON** (on)

- You can also change the dimmer setting by pressing and holding /DIMMER. 

Customizing the illumination color

You can create custom illumination colors for both **KEY COLOUR** and **DISP COLOUR**.

1 Press M.C. to display the main menu.

2 Turn M.C. to display ILLUMI and press to select.

3 Turn M.C. to display KEY COLOUR or DISP COLOUR. Press to select.

4 Press M.C. and hold until the customizing illumination color setting appears in the display.

5 Press M.C. to select the primary color.

R (red)—**G** (green)—**B** (blue)

6 Turn M.C. to adjust the brightness level.

Adjustment range: **0** to **60**

- You cannot select a level below **20** for all three of **R** (red), **G** (green), and **B** (blue) at the same time.
- You can also perform the same operation on other colors.

Note

You cannot create a custom illumination color while **SCAN**, **WARM**, **AMBIENT** or **CALM** is selected. 

About MIXTRAX

MIXTRAX technology is used to insert a variety of sound effects in between songs, allowing you to experience your music as a nonstop mix complete with visual and lighting effects.

Notes

- Depending on the file/song, sound effects may not be added.
- MIXTRAX includes a MIXTRAX flashing color mode that when switched on turns the flashing colors on and off in time with the audio track. If you find the feature distracting while driving, please turn MIXTRAX off. Refer to *Operations using the MIXTRAX button* on page 8. 

MIXTRAX menu

1 Press M.C. to display the main menu.

2 Turn M.C. to change the menu option and press to select MIXTRAX.

3 Turn M.C. to select the MIXTRAX function.

Once selected, the following MIXTRAX functions can be adjusted. The function is enabled when MIXTRAX is on.

Operating this unit

SHORT PLAYBACK (short playback mode)

You can select the length of the playback time.

- ① Press **M.C.** to display the setting mode.
- ② Turn **M.C.** to select the desired setting.
 - 1.0 MIN** (1.0 minute)—**1.5 MIN** (1.5 minutes)—
 - 2.0 MIN** (2.0 minutes)—**2.5 MIN** (2.5 minutes)—
 - 3.0 MIN** (3.0 minutes)—**OFF** (off)
- Turn this option **OFF** if you want to play a selection all the way through from start to finish.

FLASH AREA (flash area)

You can select areas for flashing colors.

- ① Press **M.C.** to display the setting mode.
- ② Turn **M.C.** to select the desired setting.
 - KEY/DISPLAY** (key and display)—**KEY** (key)—**OFF** (off)
- When **OFF** is selected, the color set under **ILLUMI** is used as the display color.

FLASH PATTERN (flash pattern)

You can select flashing color patterns.

- ① Press **M.C.** to display the setting mode.
 - ② Turn **M.C.** to select the desired setting.
- You can select any one of the options in the following list:
- **SOUND LEVEL 1 to SOUND LEVEL 6** – Flashing colors will flash on and off in synchronization with the sound level in a song. Select the desired mode.
 - **LOW PASS 1 to LOW PASS 6** – Flashing colors will flash on and off in synchronization with the bass level in a song. Select the desired mode.
 - **RANDOM 1** – The pattern for the flashing colors is randomly selected from the sound level mode and low pass mode.
 - **RANDOM 2** – The pattern for the flashing colors is randomly selected from the sound level mode.
 - **RANDOM 3** – The pattern for the flashing colors is randomly selected from the low pass mode.

DISPLAY FX (display effect)

The MIXTRAX special effects display can be turned on or off.

- ① Press **M.C.** to select the desired setting.
 - ON** (MIXTRAX special effects display)—**OFF** (normal display)

CUT IN FX (manual cut-in effect)

You can turn on or off the MIXTRAX sound effects while manually changing tracks.

- ① Press **M.C.** to select the desired setting.
 - ON** (on)—**OFF** (off)

Initial menu

1 Press and hold SRC/OFF until the unit turns off.

2 Press and hold SRC/OFF until the main menu appears in the display.

3 Turn M.C. to change the menu option and press to select INITIAL.

4 Turn M.C. to select the initial menu function.

Once selected, the following initial menu functions can be adjusted.

FM STEP (FM tuning step)

Normally, the FM tuning step employed by seek tuning is 50 kHz. When AF or TA is on, the tuning step automatically changes to 100 kHz. It may be preferable to set the tuning step to 50 kHz when AF is on.

- The tuning step remains at 50 kHz during manual tuning.
- ① Press **M.C.** to select the FM tuning step.
 - 50** (50 kHz)—**100** (100 kHz)

SP-P/O MODE (rear output and preout setting)

Operating this unit

The rear speaker leads output and the RCA output of this unit can be used to connect a full-range speaker or subwoofer. Select a suitable option for your connection.

1 Press **M.C.** to display the setting mode.

2 Turn **M.C.** to select the desired setting.

You can select any one of the options in the following list:

- **REAR/SUB.W** – Select when there is a full-range speaker connected to the rear speaker leads output and there is a subwoofer connected to the RCA output.
- **SUB.W/SUB.W** – Select when there is a subwoofer connected directly to the rear speaker leads output without any auxiliary amp and there is a subwoofer connected to the RCA output.
- **REAR/REAR** – Select when there is a full-range speaker connected to the rear speaker leads output and the RCA output. If there is a full-range speaker connected to the rear speaker leads output and the RCA output is not used, you may select either **REAR/SUB.W** or **REAR/REAR**.

S/W UPDATE (updating the software)

This function is used to update this unit with the latest Bluetooth software. For about Bluetooth software and updating, refer to our website.

- Never turn the unit off while the Bluetooth software is being updated.

1 Press **M.C.** to display the data transfer mode.

Follow the on-screen instructions to finish updating the Bluetooth software.



System menu

1 Press and hold **SRC/OFF** until the unit turns off.

2 Press and hold **SRC/OFF** until the main menu appears in the display.

3 Turn **M.C.** to change the menu option and press to select **SYSTEM**.

4 Turn **M.C.** to select the system menu function.

For details, refer to *System menu* on page 17.

Using an AUX source

1 Insert the stereo mini plug into the **AUX** input jack.

2 Press **SRC/OFF** to select **AUX** as the source.

Note

AUX cannot be selected unless the auxiliary setting is turned on. For more details, refer to **AUX (auxiliary input)** on page 18.

Switching the display

Selecting the desired text information

1 Press **DISP** to cycle between the following:

- Source name
- Source name and clock



If an unwanted display appears

Turn off the unwanted display using the procedures listed below.

1 Press **M.C.** to display the main menu.

2 Turn **M.C.** to change the menu option and press to select **SYSTEM**.

3 Turn **M.C.** to display **DEMO OFF** and press to select.

4 Turn **M.C.** to switch to **YES**.

5 Press **M.C.** to select.

Additional information

Troubleshooting

Symptom	Cause	Action
The display automatically returns to the ordinary display.	You did not perform any operation within about 30 seconds.	Perform operation again.
The repeat play range changes unexpectedly.	Depending on the repeat play range, the selected range may change when another folder or track is being selected or during fast forwarding/reversing.	Select the repeat play range again.
A subfolder is not played back.	Subfolders cannot be played when FLD (folder repeat) is selected.	Select another repeat play range.
NO XXXX appears when a display is changed (NO TITLE , for example).	There is no embedded text information.	Switch the display or play another track/file.
The unit is malfunctioning. There is interference.	You are using a device, such as a cellular phone, that transmits electric waves near the unit.	Move electrical devices that may be causing the interference away from the unit.

Symptom	Cause	Action
The sound from the Bluetooth audio source is not played back.	There is a call in progress on a Bluetooth connected cellular phone. A Bluetooth connected cellular phone is currently being operated.	The sound will be played back when the call is terminated. Do not operate the cellular phone at this time.
	A call was made with a Bluetooth connected cellular phone and then immediately terminated. As a result, communication between this unit and the cellular phone was not terminated properly.	Reconnect the Bluetooth connection between this unit and the cellular phone.



Error messages

When you contact your dealer or your nearest Pioneer Service Center, be sure to note the error message.

Common

Message	Cause	Action
AMP ERROR	Unit fails to operate or speaker connection is incorrect; protective circuit is activated.	Check the speaker connection. If the message fails to disappear even after the engine is switched off/on, contact your dealer or an authorized Pioneer Service Station for assistance.

CD player

Message	Cause	Action
ERROR-07, 11, 12, 17, 30	The disc is dirty. The disc is scratched.	Clean the disc. Replace the disc.

Additional information

Message	Cause	Action
ERROR-07, 10, 11, 12, 15, 17, 30, A0	There is an electrical or mechanical error.	Turn the ignition switch OFF and back ON, or switch to a different source, then back to the CD player.
ERROR-15	The inserted disc is blank.	Replace the disc.
ERROR-23	Unsupported CD format.	Replace the disc.
FORMAT READ	Sometimes there is a delay between the start of playback and when you start to hear any sound.	Wait until the message disappears and you hear sound.
NO AUDIO	The inserted disc does not contain any playable files.	Replace the disc.
SKIPPED	The inserted disc contains DRM protected files.	Replace the disc.
PROTECT	All the files on the inserted disc are embedded with DRM.	Replace the disc.

USB storage device/iPod

Message	Cause	Action
FORMAT READ	Sometimes there is a delay between the start of playback and when you start to hear any sound.	Wait until the message disappears and you hear sound.
NO AUDIO	There are no songs.	Transfer the audio files to the USB storage device and connect.
	The connected USB storage device has security enabled.	Follow the USB storage device instructions to disable the security.

Message	Cause	Action
SKIPPED	The connected USB storage device contains files embedded with Windows Media Media™ DRM 9/10.	Play an audio file not embedded with Windows Media DRM 9/10.
PROTECT	All the files in the USB storage device are embedded with Windows Media DRM 9/10.	Transfer audio files not embedded with Windows Media DRM 9/10 to the USB storage device and connect.
N/A USB	The USB device connected to is not supported by this unit.	<ul style="list-style-type: none"> • Connect a USB Mass Storage Class compliant device. • Disconnect your device and replace it with a compatible USB storage device.
CHECK USB	The USB connector or USB cable has short-circuited.	Check that the USB connector or USB cable is not caught in something or damaged.
CHECK USB	The connected USB storage device consumes more than maximum allowable current.	Disconnect the USB storage device and do not use it. Turn the ignition switch to OFF, then to ACC or ON and then connect only compliant USB storage devices.
CHECK USB	The iPod operates correctly but does not charge.	Make sure the connection cable for the iPod has not shorted out (e.g., not caught in metal objects). After checking, turn the ignition switch OFF and back ON, or disconnect the iPod and reconnect.

Additional information

Message	Cause	Action
ERROR-19	Communication failed.	Perform one of the following operations. –Turn the ignition switch OFF and back ON. –Disconnect the USB storage device. –Change to a different source. Then, return to the USB source.
	iPod failure.	Disconnect the cable from the iPod. Once the iPod's main menu is displayed, reconnect the iPod and reset it.
ERROR-23	USB storage device was not formatted with FAT12, FAT16 or FAT32.	USB storage device should be formatted with FAT12, FAT16 or FAT32.
ERROR-16	The iPod firmware version is old.	Update the iPod version.
	iPod failure.	Disconnect the cable from the iPod. Once the iPod's main menu is displayed, reconnect the iPod and reset it.
STOP	There are no songs in the current list.	Select a list that contains songs.
NOT FOUND	No related songs.	Transfer songs to the iPod.

Bluetooth device

Message	Cause	Action
ERROR-10	The power failed for the Bluetooth module of this unit.	Turn the ignition switch OFF and then to ACC or ON. If the error message is still displayed after performing the above action, please contact your dealer or an authorized Pioneer Service Station.

Handling guidelines

Discs and player

Use only discs that feature either of the following two logos.



Use 12-cm discs. Do not use 8-cm discs or an adapter for 8-cm discs.

Use only conventional, fully circular discs. Do not use shaped discs.



Do not insert anything other than a CD into the CD loading slot.

Do not use cracked, chipped, warped, or otherwise damaged discs as they may damage the player.

Unfinalized CD-R/RW discs cannot be played back.

Do not touch the recorded surface of the discs.

Store discs in their cases when not in use.

Do not attach labels, write on or apply chemicals to the surface of the discs.

Additional information

To clean a CD, wipe the disc with a soft cloth outward from the center.

Condensation may temporarily impair the player's performance. Let it rest for about one hour to adjust to a warmer temperature. Also, wipe any damp discs off with a soft cloth.

Playback of discs may not be possible because of disc characteristics, disc format, recorded application, playback environment, storage conditions, and so on.

Road shocks may interrupt disc playback.

Read the precautions for discs before using them.

When using discs that can be printed on label surfaces, check the instructions and the warnings of the discs. Depending on the discs, inserting and ejecting may not be possible. Using such discs may result in damage to this equipment.

Do not attach commercially available labels or other materials to the discs.

- The discs may warp making the disc unplayable.
- The labels may come off during playback and prevent ejection of the discs, which may result in damage to the equipment.

USB storage device

Address any questions you have about your USB storage device to the manufacturer of the device.

Connections via USB hub are not supported.

Do not connect anything other than a USB storage device.

Firmly secure the USB storage device when driving. Do not let the USB storage device fall onto the floor, where it may become jammed under the brake or accelerator pedal.

Depending on the USB storage device, the following problems may occur.

- Operations may vary.
- The storage device may not be recognized.
- Files may not be played back properly.
- The device may generate noise in the radio.

iPod

Do not leave the iPod in places with high temperatures.

To ensure proper operation, connect the dock connector cable from the iPod directly to this unit.

Firmly secure the iPod when driving. Do not let the iPod fall onto the floor, where it may become jammed under the brake or accelerator pedal.

About iPod settings

- When an iPod is connected, this unit changes the EQ (equalizer) setting of the iPod to off in order to optimize the acoustics. When you disconnect the iPod, the EQ returns to the original setting.
- You cannot set Repeat to off on the iPod when using this unit. Repeat is automatically changed to All when the iPod is connected to this unit.

Incompatible text saved on the iPod will not be displayed by the unit.

DualDiscs

DualDiscs are two-sided discs that have a recordable CD for audio on one side and a recordable DVD for video on the other.

Since the CD side of DualDiscs is not physically compatible with the general CD standard, it may not be possible to play the CD side with this unit.

Frequent loading and ejecting of a DualDisc may result in scratches on the disc. Serious scratches can lead to playback problems on this unit. In some cases, a DualDisc may become stuck in the disc loading slot and will not eject. To prevent this, we recommend you refrain from using DualDisc with this unit. Please refer to the information from the disc manufacturer for more detailed information about DualDiscs.



Compressed audio compatibility (disc, USB)

WMA

File extension: .wma

Bit rate: 48 kbps to 320 kbps (CBR), 48 kbps to 384 kbps (VBR)

Sampling frequency: 32 kHz, 44.1 kHz, 48 kHz

Windows Media Audio Professional, Lossless, Voice/DRM Stream/Stream with video: Not compatible

Additional information

MP3

File extension: .mp3

Bit rate: 8 kbps to 320 kbps (CBR), VBR

Sampling frequency: 8 kHz to 48 kHz (32 kHz, 44.1 kHz, 48 kHz for emphasis)

Compatible ID3 tag version: 1.0, 1.1, 2.2, 2.3, 2.4 (ID3 tag Version 2.x is given priority over Version 1.x.)

M3u playlist: Not compatible

MP3i (MP3 interactive), mp3 PRO: Not compatible

WAV

File extension: .wav

Quantization bits: 8 and 16 (LPCM), 4 (MS ADPCM)

Sampling frequency: 16 kHz to 48 kHz (LPCM), 22.05 kHz and 44.1 kHz (MS ADPCM)

Supplemental information

Only the first 32 characters can be displayed as a file name (including the file extension) or a folder name.

Russian text to be displayed on this unit should be encoded in one of the following character sets:

- Unicode (UTF-8, UTF-16)
- A character set other than Unicode that is used in a Windows environment and is set to Russian in the multi-language setting

This unit may not operate correctly depending on the application used to encode WMA files.

There may be a slight delay at the start of playback of audio files embedded with image data or audio files stored on a USB storage device that has numerous folder hierarchies.

Disc

Playable folder hierarchy: up to eight tiers (A practical hierarchy is less than two tiers.)

Playable folders: up to 99

Playable files: up to 999

File system: ISO 9660 Level 1 and 2, Romeo, Joliet

Multi-session playback: Compatible

Packet write data transfer: Not compatible

Regardless of the length of blank sections between the songs from the original recording, compressed audio discs play with a short pause between songs.

USB storage device

Playable folder hierarchy: up to eight tiers (A practical hierarchy is less than two tiers.)

Playable folders: up to 500

Playable files: up to 15 000

Playback of copyright-protected files: Not compatible

Partitioned USB storage device: Only the first partition can be played.

There may be a slight delay when starting playback of audio files on a USB storage device with numerous folder hierarchies.

CAUTION

- Pioneer cannot guarantee compatibility with all USB mass storage devices and assumes no responsibility for any loss of data on media players, smart phones, or other devices while using this product.
- Do not leave discs or a USB storage device in any place that is subject to high temperatures. 

iPod compatibility

This unit supports only the following iPod models. Supported iPod software versions are shown below. Older versions may not be supported.

Made for

- iPod touch 4th generation (software version 5.1.1)
- iPod touch 3rd generation (software version 5.1.1)
- iPod touch 2nd generation (software version 4.2.1)
- iPod touch 1st generation (software version 3.1.3)
- iPod classic 160GB (software version 2.0.4)

Additional information

- iPod classic 120GB (software version 2.0.1)
- iPod classic (software version 1.1.2)
- iPod with video (software version 1.3.0)
- iPod nano 6th generation (software version 1.2)
- iPod nano 5th generation (software version 1.0.2)
- iPod nano 4th generation (software version 1.0.4)
- iPod nano 3rd generation (software version 1.1.3)
- iPod nano 2nd generation (software version 1.1.3)
- iPod nano 1st generation (software version 1.3.1)
- iPhone 4S (software version 5.1.1)
- iPhone 4 (software version 5.1.1)
- iPhone 3GS (software version 5.1.1)
- iPhone 3G (software version 4.2.1)
- iPhone (software version 3.1.2)

Depending on the generation or version of the iPod, some functions may not be available.

Operations may vary depending on the software version of iPod.

When using an iPod, an iPod Dock Connector to USB Cable is required.

A Pioneer CD-IU51 interface cable is also available. For details, consult your dealer.

About the file/format compatibility, refer to the iPod manuals.

Audiobook, Podcast: Compatible

CAUTION

Pioneer accepts no responsibility for data lost on the iPod, even if that data is lost while this unit is used. 

Sequence of audio files

The user cannot assign folder numbers and specify playback sequences with this unit.

Example of a hierarchy

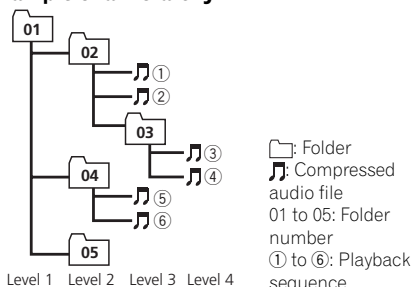

Disc

Folder selection sequence or other operation may differ depending on the encoding or writing software.

USB storage device

Playback sequence is the same as recorded sequence in the USB storage device.

To specify the playback sequence, the following method is recommended.

- 1 Create a file name that includes numbers that specify the playback sequence (e.g., 001xxx.mp3 and 099yyy.mp3).
- 2 Put those files into a folder.
- 3 Save the folder containing files on the USB storage device.

However, depending on the system environment, you may not be able to specify the playback sequence.

For USB portable audio players, the sequence is different and depends on the player. 

Russian character chart

D: C	D: C	D: C	D: C	D: C
А: А	Б: Б	В: В	Г: Г	Д: Д
Е: Е, Ё	Ж: Ж	З: З	И: И, Й	К: К
Л: Л	М: М	Н: Н	О: О	П: П
Р: Р	С: С	Т: Т	У: У	Ф: Ф

Additional information

D: C	D: C	D: C	D: C	D: C
#: X	#: Ц	#: Ч	#: Ш, Щ	#: Ъ
#: Ъ	#: Ь	#: Э	#: Ю	#: Я

D: Display C: Character



Bluetooth profiles

In order to use Bluetooth wireless technology, devices must be able to interpret certain profiles. This unit is compatible with the following profiles.

- GAP (Generic Access Profile)
- OPP (Object Push Profile)
- HFP (Hands Free Profile) 1.5
- HSP (Head Set Profile)
- PBAP (Phone Book Access Profile)
- A2DP (Advanced Audio Distribution Profile)
- AVRCP (Audio/Video Remote Control Profile) 1.3

Copyright and trademark

Bluetooth

The *Bluetooth*[®] word mark and logos are registered trademarks owned by Bluetooth SIG, Inc. and any use of such marks by PIONEER CORPORATION is under license. Other trademarks and trade names are those of their respective owners.

iTunes

Apple and iTunes are trademarks of Apple Inc., registered in the U.S. and other countries.

MP3

Supply of this product only conveys a license for private, non-commercial use and does not convey a license nor imply any right to use this product in any commercial (i.e. revenue-generating) real time broadcasting (terrestrial, satellite, cable and/or any other media), broadcasting/streaming via internet, intranets and/

or other networks or in other electronic content distribution systems, such as pay-audio or audio-on-demand applications. An independent license for such use is required. For details, please visit <http://www.mp3licensing.com>.

WMA

Windows Media is either a registered trademark or trademark of Microsoft Corporation in the United States and/or other countries. This product includes technology owned by Microsoft Corporation and cannot be used or distributed without a license from Microsoft Licensing, Inc.

iPod & iPhone

iPhone, iPod, iPod classic, iPod nano, and iPod touch are trademarks of Apple Inc., registered in the U.S. and other countries. "Made for iPod" and "Made for iPhone" mean that an electronic accessory has been designed to connect specifically to iPod or iPhone, respectively, and has been certified by the developer to meet Apple performance standards. Apple is not responsible for the operation of this device or its compliance with safety and regulatory standards. Please note that the use of this accessory with iPod or iPhone may affect wireless performance.

MIXTRAX

MIXTRAX is a trademark of the PIONEER CORPORATION.

Additional information

Specifications

General

Power source	14.4 V DC (10.8 V to 15.1 V allowable)
Grounding system	Negative type
Maximum current consumption	10.0 A
Dimensions (W × H × D):	
DIN	
Chassis	178 mm × 100 mm × 157 mm
Nose	188 mm × 118 mm × 25 mm
D	
Chassis	178 mm × 100 mm × 165 mm
Nose	170 mm × 96 mm × 17 mm
Weight	1.2 kg

Audio

Maximum power output	50 W × 4 70 W × 1/2 Ω (for subwoofer)
Continuous power output	22 W × 4 (50 Hz to 15 000 Hz, 5 % THD, 4 Ω load, both channels driven)
Load impedance	4 Ω (4 Ω to 8 Ω allowable)
Preout maximum output level	2.0 V
Loudness contour	+10 dB (100 Hz), +6.5 dB (10 kHz) (volume: -30 dB)
Equalizer (5-Band Graphic Equalizer):	
Frequency	80 Hz/250 Hz/800 Hz/ 2.5 kHz/8 kHz
Equalization range	±12 dB (2 dB step)
Subwoofer (mono):	
Frequency	50 Hz/63 Hz/80 Hz/100 Hz/ 125 Hz/160 Hz/200 Hz
Slope	-6 dB/oct, -12 dB/oct
Gain	+6 dB to -24 dB
Phase	Normal/Reverse

CD player

System	Compact disc audio system
Usable discs	Compact disc
Signal-to-noise ratio	94 dB (1 kHz) (IEC-A network)
Number of channels	2 (stereo)
MP3 decoding format	MPEG-1 & 2 Audio Layer 3
WMA decoding format	Ver. 7, 7.1, 8, 9, 10, 11, 12 (2 ch audio) (Windows Media Player)

WAV signal format	Linear PCM & MS ADPCM (Non-compressed)
-------------------------	--

USB

USB standard specification	USB 2.0 full speed
Maximum current supply	1 A
USB Class	MSC (Mass Storage Class)
File system	FAT12, FAT16, FAT32
MP3 decoding format	MPEG-1 & 2 Audio Layer 3
WMA decoding format	Ver. 7, 7.1, 8, 9, 10, 11, 12 (2 ch audio) (Windows Media Player)
WAV signal format	Linear PCM & MS ADPCM (Non-compressed)

FM tuner

Frequency range	87.5 MHz to 108.0 MHz
Usable sensitivity	9 dBf (0.8 μV/75 Ω mono, S/N: 30 dB)
Signal-to-noise ratio	72 dB (IEC-A network)

MW tuner

Frequency range	531 kHz to 1 602 kHz
Usable sensitivity	25 μV (S/N: 20 dB)
Signal-to-noise ratio	62 dB (IEC-A network)

LW tuner

Frequency range	153 kHz to 281 kHz
Usable sensitivity	28 μV (S/N: 20 dB)
Signal-to-noise ratio	62 dB (IEC-A network)

Bluetooth

Version	Bluetooth 3.0 certified
Output power	+4 dBm Maximum (Power class 2)

Note

Specifications and the design are subject to modifications without notice. 

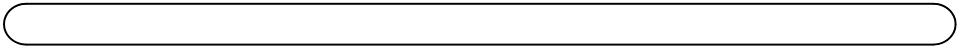

<http://www.pioneer.eu>

Visit www.pioneer.co.uk (or www.pioneer.eu) to register your product.

PIONEER CORPORATION

1-1, Shin-ogura, Saiwai-ku, Kawasaki-shi,
Kanagawa 212-0031, JAPAN

PIONEER EUROPE NV

Haven 1087, Keetberglaan 1, B-9120 Melsele, Belgium/Belgique
TEL: (0) 3/570.05.11

PIONEER ELECTRONICS (USA) INC.

P.O. Box 1540, Long Beach, California 90801-1540, U.S.A.
TEL: (800) 421-1404

PIONEER ELECTRONICS OF CANADA, INC.

340 Ferrier Street, Unit 2, Markham, Ontario L3R 2Z5, Canada
TEL: 1-877-283-5901
TEL: 905-479-4411

PIONEER ELECTRONICS ASIACENTRE PTE. LTD.

253 Alexandra Road, #04-01, Singapore 159936
TEL: 65-6472-7555

PIONEER ELECTRONICS AUSTRALIA PTY. LTD.

5 Arco Lane, Heatherton, Victoria, 3202 Australia
TEL: (03) 9586-6300

PIONEER ELECTRONICS DE MEXICO, S.A. de C.V.

Blvd.Manuel Avila Camacho 138 10 piso
Col.Lomas de Chapultepec, Mexico, D.F. 11000
TEL: 55-9178-4270

先鋒股份有限公司

台北市內湖區瑞光路407號8樓
電話：886-(0)2-2657-3588

先鋒電子（香港）有限公司

香港九龍長沙灣道909號5樓
電話：852-2848-6488

© 2012 PIONEER CORPORATION.
All rights reserved.