

Pioneer

VREC-DH300D

DASH CAMERA

English

Owner's Manual

Contents

Thank you for buying this Pioneer product.
Please read through these instructions so you will know how to operate your model properly. After you have finished reading the instructions, keep this document in a safe place for future reference.

Precaution	5
Safety Precautions.....	5
Disclaimer	8
How to read this Manual	9
Usage Precautions	10
Check the Accessories	12
When Replacing the Fuse.....	12
Before Installing the Product	13
Installation Precautions.....	13
Installation Tips.....	14
Installation	15
Specified Installation Position on Front Windscreen.....	15
Recommended Installation Position on Rear Windscreen.....	16
Install this product.....	16
Install the Rear Camera.....	18
Connecting the Cables	19
Part Names	21
Function Buttons.....	22
Inserting and Ejecting the microSD Card	23
Inserting the microSD Card.....	23
Ejecting the microSD Card.....	23
Backing Up Recorded Files	24
Folder and File Structure.....	24
Using this product	25
This Product Power.....	25
System Indicator Display.....	25
How to View the Recording Screen.....	26
Video Recording.....	26
Event Recording.....	26
Playing Recorded Files.....	27
This Product Settings	30
Configurable Features.....	32
Guide to Recording Time	34
Troubleshooting	35
Specifications	36
GPS	37
Trademarks & Copyrights	38

Declaration of Conformity with regard to the Radio Equipment Directive 2014/53/EU

Manufacturer:

Pioneer Corporation

28-8, Honkomagome 2-chome, Bunkyo-ku,
Tokyo 113-0021, JAPAN

EU Authorised Representative's & Importer:

Pioneer Europe NV

Haven 1087, Keetberglaan 1, B-9120 Melsele, Belgium/Belgique
<http://www.pioneer-car.eu>

[*] VREC-DH300D

English:

Hereby, Pioneer declares that the radio equipment type [*] is in compliance with Directive 2014/53/EU.

The full text of the EU declaration of conformity is available at the following internet address:

<https://www.pioneer-car.eu/eur/compliance>

Suomi:

Pioneer vakuuttaa, että radiolaitetyyppi [*] on direktiivin 2014/53/EU mukainen.

EU-vaatimustenmukaisuusvakuutuksen täysimittainen teksti on saatavilla seuraavassa internetosoitteessa:

<https://www.pioneer-car.eu/eur/compliance>

Nederlands:

Hierbij verklaar ik, Pioneer, dat het type radioapparatuur [*] conform is met Richtlijn 2014/53/EU.

De volledige tekst van de EU-conformiteitsverklaring kan worden geraadpleegd op het volgende internetadres:

<https://www.pioneer-car.eu/eur/compliance>

Français:

Le soussigné, Pioneer, déclare que l'équipement radioélectrique du type [*] est conforme à la directive 2014/53/UE.

Le texte complet de la déclaration UE de conformité est disponible à l'adresse internet suivante:

<https://www.pioneer-car.eu/eur/compliance>

Svenska:

Härmed försäkrar Pioneer att denna typ av radioutrustning [*] överensstämmer med direktiv 2014/53/EU.

Den fullständiga texten till EU-försäkran om överensstämmelse finns på följande webbadress:

<https://www.pioneer-car.eu/eur/compliance>

Dansk:

Hermed erklærer Pioneer, at radioudstyrstypen [*] er i overensstemmelse med direktiv 2014/53/EU.

EU-overensstemmelseserklæringens tekst kan findes på følgende internetadresse:

<https://www.pioneer-car.eu/eur/compliance>

Deutsch:

Hiermit erkläre Pioneer, dass der Funkanlagentyp [Bezeichnung] der Richtlinie 2014/53/EU entspricht.

Der vollständige Text der EU-Konformitätserklärung ist unter der folgenden Internetadresse verfügbar:

<https://www.pioneer-car.eu/eur/compliance>

Ελληνικά:

Με την παρούσα ο/η Pioneer, δηλώνει ότι ο ραδιοεξοπλισμός [*] πληροί την οδηγία 2014/53/ΕΕ.

Το πλήρες κείμενο της δήλωσης συμμόρφωσης ΕΕ διατίθεται στην ακόλουθη ιστοσελίδα στο διαδίκτυο:

<https://www.pioneer-car.eu/eur/compliance>

Italiano:

Il fabbricante, Pioneer, dichiara che il tipo di apparecchiatura radio [*] è conforme alla direttiva 2014/53/UE.

Il testo completo della dichiarazione di conformità UE è disponibile al seguente indirizzo Internet:

<https://www.pioneer-car.eu/eur/compliance>

Español:

Por la presente, Pioneer declara que el tipo de equipo radioeléctrico [*] es conforme con la Directiva 2014/53/UE.

El texto completo de la declaración UE de conformidad está disponible en la dirección Internet siguiente:

<https://www.pioneer-car.eu/eur/compliance>

Português:

O(a) abaixo assinado(a) Pioneer declara que o presente tipo de equipamento de rádio [*] está em conformidade com a Diretiva 2014/53/UE.

O texto integral da declaração de conformidade está disponível no seguinte endereço de Internet:

<https://www.pioneer-car.eu/eur/compliance>

Čeština:

Tímto Pioneer prohlašuje, že typ rádiového zařízení [*] je v souladu se směrnicí 2014/53/EU.

Úplné znění EU prohlášení o shodě je k dispozici na této internetové adrese:

<https://www.pioneer-car.eu/eur/compliance>

Eesti:

Käesolevaga deklareerib Pioneer, et käesolev raadioseadme tüüp [*] vastab direktiivi 2014/53/EU nõuetele.

El'i vastavusdeklaratsiooni täielik tekst on kätesaadav järgmisel internetiaadressil:

<https://www.pioneer-car.eu/eur/compliance>

Magyar:

Pioneer igazolja, hogy a [*] típusú rádióberendezés megfelel a 2014/53/EU irányelvnek.
Az EU-megfelelőségi nyilatkozat teljes szövege elérhető a következő internetes címen:
<https://www.pioneer-car.eu/eur/compliance>

Latviešu valoda:

Ar šo Pioneer deklarē, ka radioiekārta [*] atbilst Direktīvai 2014/53/ES.
Pilns ES atbilstības deklarācijas teksts ir pieejams šādā interneta vietnē:
<https://www.pioneer-car.eu/eur/compliance>

Lietuvių kalba:

Aš, Pioneer, patvirtinu, kad radijo įrenginių tipas [*] atitinka Direktyvą 2014/53/ES.
Visas ES atitikties deklaracijos tekstas prieinamas šiuo interneto adresu:
<https://www.pioneer-car.eu/eur/compliance>

Malti:

B'dan, Pioneer, niddikjara li dan it-tip ta' taghmir tar-radju [*] huwa konformi mad-Direttiva 2014/53/UE.
It-test kollu tad-dikjarazzjoni ta' konformita' tal-UE huwa disponibbli f'dan l-indirizz tal-Internet li ġej:
<https://www.pioneer-car.eu/eur/compliance>

Slovenčina

Pioneer týmto vyhlasuje, že rádiové zariadenie typu [*] je v súlade so smernicou 2014/53/EÚ.
Úplné EÚ vyhlásenie o zhode je k dispozícii na tejto internetovej adrese:
<https://www.pioneer-car.eu/eur/compliance>

Slovenščina:

Pioneer potrjuje, da je tip radijske opreme [*] skladen z Direktivo 2014/53/EU.
Celotno besedilo izjave EU o skladnosti je na voljo na naslednjem spletnem naslovu:
<https://www.pioneer-car.eu/eur/compliance>

Română:

Prin prezenta, Pioneer declară că tipul de echipamente radio [*] este în conformitate cu Directiva 2014/53/UE.
Textul integral al declarației UE de conformitate este disponibil la următoarea adresă internet:
<https://www.pioneer-car.eu/eur/compliance>

Български:

С настоящото Pioneer декларира, че този тип радиосъоръжение [*] е в съответствие с Директива 2014/53/ЕС.
Цялостният текст на ЕС декларацията за съответствие може да се намери на следния интернет адрес:
<https://www.pioneer-car.eu/eur/compliance>

Polski:

Pioneer niniejszym oświadcza, że typ urządzenia radiowego [*] jest zgodny z dyrektywą 2014/53/UE.
Pełny tekst deklaracji zgodności UE jest dostępny pod następującym adresem internetowym:
<https://www.pioneer-car.eu/eur/compliance>

Norsk:

Herved Pioneer erklærer at radioutstyr type [*] er i samsvar med direktiv 2014/53 / EU.
Den fullstendige teksten i EU-samsvarserklæringen er tilgjengelig på følgende internetadresse :
<https://www.pioneer-car.eu/eur/compliance>

Íslenska:

Hér með Pioneer lýsir yfir að tegund bráðlausan búnað [*] er í samræmi við tilskipun 2014/53/ESB.
The fullur texti af ESB-samræmisýfirlýsingu er í boði á eftirfarandi veffangi:
<https://www.pioneer-car.eu/eur/compliance>

Hrvatski:

Pioneer ovime izjavljuje da je radijska oprema tipa [*] u skladu s Direktivom 2014/53/EU.
Cjeloviti tekst EU izjave o sukladnosti dostupan je na sljedećoj internetskoj adresi:
<https://www.pioneer-car.eu/eur/compliance>

Türk:

Burada, Pioneer radyo ekipmanı turunun [*] 2014/53/EU direktiflerine uyumlu olduğunu beyan eder.
Avrupa uyumluluk beyanının tam metni belirtilen internet sitesinde mevcuttur :
<https://www.pioneer-car.eu/eur/compliance>

Precaution

Certain country and state laws may prohibit or restrict the placement and use of this product in your vehicle. Please comply with all applicable laws and regulations regarding the use, installation and operation of this product. It is the user's responsibility in compliance with all applicable laws and ordinance.

Information for users on collection and disposal of old equipment and used batteries

(Symbol for equipment)



(Symbol examples for batteries)



These symbols on the products, packaging, and/or

accompanying documents mean that used electrical and electronic products and batteries should not be mixed with general household waste.

For proper treatment, recovery and recycling of old products and used batteries, please take them to applicable collection points in accordance with your national legislation.

By disposing of these products and batteries correctly, you will help to save valuable resources and prevent any potential negative effects on human health and the environment which could otherwise arise from inappropriate waste handling.

For more information about collection and recycling of old products and batteries, please contact your local municipality, your waste disposal service or the point of sale where you purchased the items

These symbols are only valid in the European Union.

For countries outside the European Union:

If you wish to discard these items, please contact your local authorities or dealer and ask for the correct method of disposal.

⚠ CAUTION

- There is a danger of explosion if the battery is incorrectly replaced. Replace only with the same or equivalent type.
- Do not expose a battery to high or low extreme temperatures during use, storage or transportation.
- Do not dispose of a battery into fire or a hot oven, or crush mechanically or cut a battery, that can result in an explosion.
- The graphical symbol  placed on the product means direct current.

⚠ WARNING

- Batteries (battery pack or batteries installed) must not be exposed to excessive heat such as sunshine, fire or the like.

Safety Precautions

Always observe the precautions described here to prevent harm to yourself and others and to prevent damage to property before it happens.

Important safeguards

⚠ WARNING

- Do not install this product in your vehicle if its location or use would obstruct the driver's clear view of the road or the operation of any vehicle airbag. It is also the driver's responsibility to know and comply with the laws, rules, and regulations of the driving location, including, for example, passenger privacy rights, and not to use the device in any location where its installation or use is prohibited.

- The laws in your location may require you to provide notice to passengers that a recording device is in use. If so, you should place the notice sticker in a location clearly visible to your passengers.
- Any obstruction of or other interference with the airbag, either deployed or non-deployed, or with the clear view of the road must be avoided and, accordingly, professional installation is required.
- We recommend that this product be set up and installed by a technician who has special training and experience in mobile electronics.

Important safety information

WARNING

- Do not allow this product to come into contact with liquids. Electrical shock could result. Also, damage to the product, smoke, and overheating could result from contact with liquids.
- If liquid or foreign matter should get inside this product, park your vehicle in a safe place, turn the ignition switch off (ACC OFF) and consult your dealer or the nearest authorised Pioneer Service Station. Do not use this product in this condition because doing so may result in a fire, electric shock, or other failure.
- If you notice smoke, a strange noise or odour from this product, or any other abnormal signs on the LCD screen, turn off the power immediately and consult your dealer or the nearest authorised Pioneer Service Station. Using this product in this condition may result in permanent damage to the system.
- Do not disassemble or modify this product, as there are high-voltage components inside which may cause an electric shock. Be sure to consult your dealer or the nearest authorised Pioneer Service Station for internal inspection, adjustments or repairs.

Before using this product, be sure to read and fully understand the following safety information:

- Do not operate this product if doing so will divert your attention in any way from the safe operation of your vehicle. Always observe safe driving rules and follow all existing traffic regulations. If you experience difficulty in operating this product or reading the display, park your vehicle in a safe location and apply the handbrake before making the necessary adjustments.
- Never set the volume of this product so high that you cannot hear outside traffic and emergency vehicles.
- Keep this manual handy as a reference for operating procedures and safety information.
- Certain functions (such as viewing of screen and certain button operations) offered by this product could be dangerous (possibly resulting in serious injury or death) and/or unlawful if used while driving. Screen display is disabled for this product while the vehicle is moving.

To ensure safe driving

WARNING

- In some countries the viewing of video image on a display inside a vehicle even by persons other than the driver may be illegal. Where such regulations apply, they must be obeyed.

Precautions before connecting the system

CAUTION

- Firmly install this product so it does not fall off the windscreen. If this product is not firmly installed, it may fall off the windscreen while driving and cause an accident. Periodically inspect this product.
- Secure all wiring with cable clamps or electrical tape. Do not allow any bare wiring to remain exposed.
- It is extremely dangerous to allow cables to become wound around the steering column or gearstick. Be sure to install this product, its cables, and wiring away in such so that they will not obstruct or hinder driving.
- Make sure that the cables and wires will not interfere with or become caught in any of the vehicle's moving parts, especially the steering wheel, gearstick, handbrake, sliding seat tracks, doors, or any of the vehicle's controls.

- Do not route wires where they will be exposed to high temperatures. If the insulation heats up, wires may become damaged, resulting in a short circuit or malfunction and permanent damage to the product.
- Do not shorten any cables. If you do, the protection circuit (fuse holder, fuse resistor or filter, etc.) may fail to work properly.
- Never feed power to other electronic products by cutting the insulation of the power supply cable of this product and tapping into the cable. The current capacity of the cable will be exceeded, causing overheating.

To prevent damage

WARNING

- When replacing the fuse, be sure to only use a fuse of the rating prescribed on this product.

Precautions before installation

CAUTION

Never install this product in places where, or in a manner that:

- Could injure the driver or passengers if the vehicle stops suddenly.
- May interfere with the driver's operation of the vehicle, such as on the floor in front of the driver's seat, or close to the steering wheel or gearstick.
- To ensure proper installation, be sure to use the supplied parts in the manner specified. If any parts are not supplied with this product, use compatible parts in the manner specified after you have the parts' compatibility checked by your dealer. If parts other than supplied or compatible ones are used, they may damage internal parts of this product or they may work loose and the product may become detached.
- Do not install this product where it may
 - (i) obstruct the driver's vision,
 - (ii) impair the performance of any of the vehicle's operating systems or safety features, including airbags, hazard lamp buttons or
 - (iii) impair the driver's ability to safely operate the vehicle.
- Never install this product in front of or next to the place in the dashboard, door, or pillar from which one of your vehicle's airbags would deploy. Please refer to your vehicle's owner's manual for reference to the deployment area of the frontal airbags.
- Consult with your nearest dealer if installation requires drilling holes or other modifications of the vehicle.
- Before making a final installation of this product, temporarily connect the wiring to confirm that the connections are correct and the system works properly.
- Do not install this product in places subject to high temperatures or humidity, such as:
 - Places close to a heater, vent or air conditioner.
 - Places that may be exposed to rain, such as close to the door or on the vehicle's floor.

Disclaimer

- Given the large number of variables and conditions that can be involved in an accident, Pioneer cannot guarantee that every accident or occurrence will trigger the recording feature in this device.
- This product features may not operate properly due to the effects of settings, how this product is installed, the condition of the microSD card, and driving conditions (including the road conditions).
- If brightly coloured objects are placed on the dashboard, they may be reflected in the front windscreen and the camera image. Do not place brightly coloured objects on the dashboard.
- This product is not guaranteed to be effective as evidence in an accident.
- This product is not guaranteed to save video in all situations.
- You may not be able to recognise the conditions in the front of the vehicle in recorded video, depending on the ambient conditions, such as the weather and time.
- LED traffic signals or street lamps on the road may appear as flashing or flickering when recorded with this product. The colour may also not be correctly identifiable. Pioneer Corporation accepts no responsibility whatsoever for these phenomena.
- This product saves video before and after an accident occurs by detecting the impact (acceleration) with the G-sensor (accelerometer). However, this product is not guaranteed to save video in all situations.
- Pioneer Corporation accepts no responsibility whatsoever for product failures or damage that occur due to the microSD card wearing out.
- Pioneer Corporation does not make any assurances that microSD card problems will be repaired by formatting the card. Pioneer Corporation bears no responsibility for files that are erased from the microSD card or damage that occurs from formatting the card. Format the microSD card according to your own judgement and at your own responsibility.
- Always install this product in the specified installation position to ensure a safe field of view while driving and to achieve full performance from the product.
Pioneer is not liable for any damage, due to installation or use of the product.

How to read this Manual

Notation	Meaning
	These symbols are used to draw your attention to items you should be aware of when using this product and items you should be aware of to maintain its performance.
Note / Notes	Notes provide useful tips and extra information about product features.
[○○]	Square brackets are used to indicate selectable items displayed on the screen.
→“○○○○”	Quotation marks are used to indicate references and settings.

- The illustrations and example screens used in this manual may differ from the actual product.
- The actual screens of the product may be changed without prior notification for the purpose of improvements to product performance and features.
- In this manual, the microSDHC/SDXC memory card is referred to as "the microSD card" for convenience.

Usage Precautions

⚠ Precautions When Handling this product

- The driver may manually set the device to save video to assist in the monitoring of driver performance.
- There are limits to the scope of video that can be recorded with this product (→ “**Specifications**”). First check the video that will be recorded before using this product.
- Do not use this product in locations subjected to high temperatures of 60°C or higher, low temperatures of -10°C or lower, or high humidity.
- Be careful not to infringe on the privacy of any subject in video recorded with this product when using said video. You are fully responsible for the use of said video. Video recorded with this product may include personal information, such as numbers on number plates.
- Be sure to use the included power cable for powering the product.
- Pioneer Corporation does not offer a data recovery service for corrupted or deleted files.
- The storage areas on the microSD card are split into the two areas shown in the following diagram according to the type of recording.

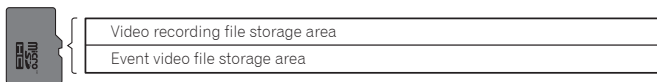

- Note that files will be overwritten when there is insufficient free space in the file storage areas. We recommend that you back up any important files you want to keep. → “**Backing Up Recorded Files**”
- To ensure that important files, such as files containing records of accidents, are not overwritten, always turn the power off before removing the microSD card and store the card in a safe place. → “**Inserting and Ejecting the microSD Card**”
- You can view video files on your PC. However, the video may stutter or stop depending on the performance of the PC.
- If this product is used near another device that uses GPS, such as a car navigation system, that device may temporarily be unable to receive radio waves from GPS satellites due to radio interference. There may also be a negative impact on the functions of surrounding devices.
- The internal battery is a consumable part. This battery is for retaining the time, and may fail to retain the time after repeated charging. Contact Pioneer support if the time resets frequently. (After purchase, charge the internal battery for approximately 1 hour.)
- Do not touch the lens with your hands. Wipe the lens off with a soft cloth if you touch it.

⚠ Precautions When Handling the microSD Card

- Keep the microSD card out of the reach of small children to prevent them from accidentally swallowing it.
- To prevent data loss and damage to the microSD card, never remove it from this product while data is being transferred.
- If data loss or corruption occurs on the microSD card for any reason, it is usually not possible to recover the data. Pioneer accepts no liability for damages, costs or expenses arising from data loss or corruption.
- Never insert or eject an microSD card while driving.

- This product supports the following microSD cards.

	microSDHC	microSDXC
Capacity	16 GB ~ 32 GB	64 GB ~ 128 GB
File system	FAT32	
Speed class	Class 10 or better	

Not all microSD cards are guaranteed to work with this product.

- Pioneer's recommended microSD cards:
Pioneer microSDHC/SDXC memory cards (sold separately).
For details, see the following product page.
www.pioneer-car.eu/eur/
- Format the microSD card before using it. Do not use a microSD card that contains other data, such as that from a PC.
- Periodically format the microSD card.
- Do not eject the microSD card when it is being accessed. The file or card may be corrupted.
- Even if the microSD card is used normally, you may no longer be able to write data to the card or erase data from the card normally.
- The service life of the microSD card is not covered under the warranty.
- The microSD card is a consumable part. We recommend that you regularly replace the microSD card with a new card. If you use the microSD card for a long period of time, this product may no longer be able to save data to the card correctly due to bad sectors, or an error may occur and the card will no longer be usable.
- On rare occasions, a microSD card that is recognised by your computer may not be recognised by this product. In this case, depending on the problem with the microSD card, this product may be able to recognise the card by formatting it with this product format feature → ***"This Product Settings" - "Configurable Features" - "System Setting" - "SD Card Format"***. However, all files, including protected files, saved to the microSD card will be erased when it is formatted. Always back up the files on the microSD card before formatting it.
- Pioneer Corporation does not make any assurances that microSD card problems will be repaired by formatting the card. Pioneer Corporation bears no responsibility for files that are erased from the microSD card or damage that occurs from formatting the card. Format the microSD card according to your own judgement and at your own responsibility.

Check the Accessories

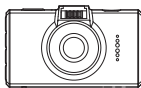

Main Unit×1



Mounting Bracket×1

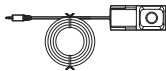

Rear Camera (3 m)×1

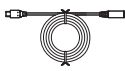
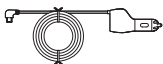
Rear Camera
Connection Cable
(6 m)×1Cigarette Lighter
Power Cable (4 m)×1microSDHC Card
(16 GB)×1

Quick Start Guide×1



Warranty×1



Cleaning Cloth×1

When Replacing the Fuse

If the product does not power on or charge even when the included cigarette lighter power cable is connected, then check if the fuse is blown.

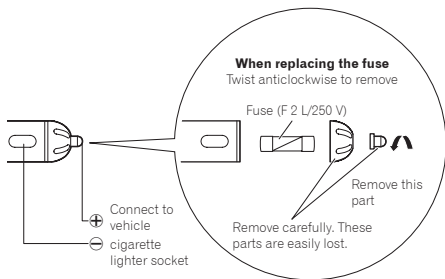

⚠ CAUTION

- If the fuse is blown, then replace this with a new standard glass tube fuse (diam. 5.0 mm/length 20 mm), and tighten the tip fully. Ensure that the fuse is replaced with one of the rated type and capacity (F 2 L/250 V).

Before Installing the Product

⚠ WARNING

- When installing the product on vehicles installed with an air bag, never install on the cover of the air bag and at locations that might obstruct the deployment of the air bag. Doing so might prevent the air bag from being deployed normally, cause the product to fly out due to air bag deployment, and cause accident and injury.

⚠ CAUTION

- First check with the vehicle manufacturer for precautions related to the installation work when installing the product in a vehicle equipped with airbags. Otherwise there is a risk of airbag malfunction.
- Always use the included parts as specified. There is a risk of product failure if other parts are used.
- Install this product in a location where it will not hinder vehicle equipment and the ability to drive the vehicle.

Installation Precautions

- The main unit and rear camera are for installation to the inside of the front and rear windows only. Do not install it anywhere else inside or outside of the vehicle.
- When installing main unit to the inside of the front windscreen, be sure to install it to the specified positions of the front windscreen and within the specified dimensions.
- When installing the rear camera to the inside of the rear window, pay attention to the following points.
 - Avoid installing the rear camera on heating wires.
 - If the vehicle is provided with a rear wiper, install so that it is within the wiping range of the wiper.
 - Install the rear camera as far as possible from the high mount stop lamp.
- Depending on the vehicle, installation at the specified location and within the specified dimensions may not be possible. For details, consult with your dealer.
- Do not cover this product and rear camera or get the lens dirty.
- Do not place reflective objects near the lens.
- Take care when handling this product and rear camera so that they do not drop and you do not touch the lens.
- Recording quality may be affected if the front windscreen of the vehicle is coated or has been specially treated.
- This product may not be able to receive GPS signals if the front windscreen of the vehicle has been specially treated. Check the GPS reception status indicator displayed on the screen of this product. If a GPS signal cannot be received, this product cannot be installed in this vehicle. → **"Using this product" - "How to View the Recording Screen"**
- Choose a working location free from dust and debris in the air.
- When the temperature is low or there is condensation on the glass, turn on the heater and defroster to warm up the window in order to prevent poor adhesion of the double-sided tape.

Double-sided tape cannot be re-applied once it is peeled off as peeling off weakens its adhesive strength. Be sure to temporarily fasten this product and rear camera and sufficiently consider routing of cables before applying double-sided tape.

Before Installing and Securing the Product

- First, temporarily connect this product and confirm that it operates correctly, and then install it. If the product does not operate correctly, check again if there is a mistake in the connection.

Before Applying Double-sided Tape

- Clean the location where the double-sided tape will be applied.

CAUTION

- Install firmly so that it does not come off.
Incorrect installation may cause this to peel off while driving and cause an accident. Inspect the installation state from time to time.

Installation

Specified Installation Position on Front Windscreen

When installing this product the inside of the front windscreen, install in a vehicle and in a position that satisfies all of the following conditions.

- A position where this entire product is within 20% of the top edge of the height of the front windscreen (range within 20% of the actual length, excluding parts overlapping weatherstrips, mouldings, etc. and masked parts) or are in the shadow of the rear view mirror as viewed from the driver's seat. Note that "20%" as described above is a rough estimate. Please install the product in accordance with your country's laws and regulations.
- A position where the lens part of this product is within the wiping range of the wiper.
- A position where the lens part of this product does not hang over the sunshade and black ceramic lines/black ceramic pattern.
- A position where this product faces in the horizontal direction to the front and side to side.
- A position where the cigarette lighter power cable can be routed without unnecessary force.

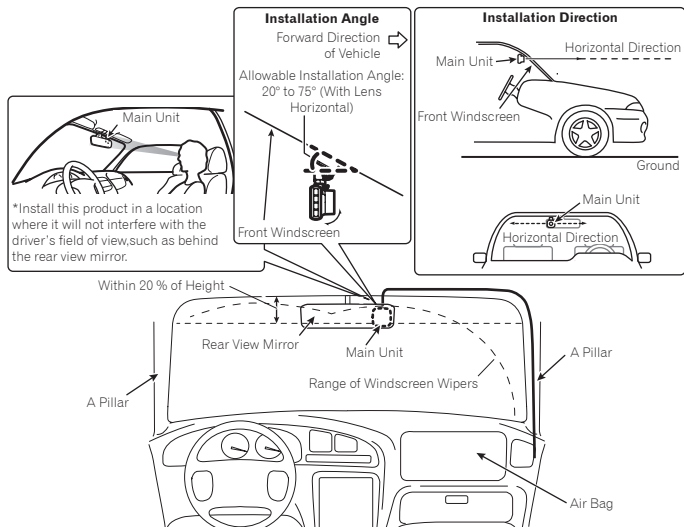

⚠ IMPORTANT

Always install this product in the specified installation position to ensure a safe field of view while driving and to achieve full performance from the product.

Pioneer is not liable for any damage, due to installation or use of the product.

Recommended Installation Position on Rear Windscreen

When installing the rear camera on the inside of the rear window, installation in a vehicle and in a position that satisfies all of the following conditions is recommended.

- A position where the lens part of the rear camera is within the wiping range of the wiper.
- A position where the rear camera faces in the horizontal direction to the rear and side to side.
- A position where the lens part of the rear camera and the double-sided tape do not overlap the heating wires.
- A position where the rear camera connection cable can be routed without unnecessary force.

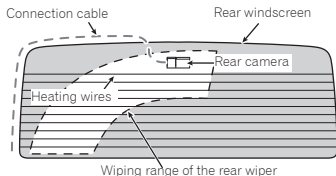

Install this product

- 1 Clean the installation area of dirt and oils using the included cleaning cloth.**

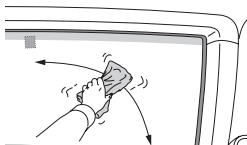

- 2 Install this product.**

- ① : Set the mounting bracket on the main unit.
- ② : Peel off the double-sided tape release paper from the mounting bracket.
- ③ : Install at the specified position of the front windscreen.

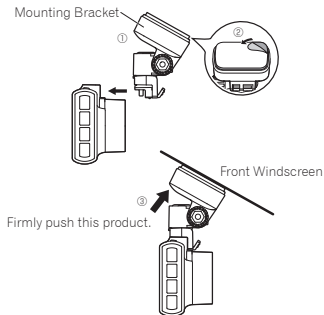

⚠ CAUTION

- Make sure that the surface of the front windscreen is clean and dry, before attaching the mounting bracket.
- Never touch the surface of the LCD.
- Use extreme care as the double-sided tape on the mounting bracket is extremely strong, and it will be difficult to reapply the tape once it has been applied.
- To ensure the installation strength of the adhesive tape, leave this product for 24 hours after application before using it.

Note

- A protective film is applied to the lens when the product is purchased. Peel off this film.

3 Adjust the installation angle.

Loosen the angle adjustment bolt to adjust. After adjusting, tighten the loosened bolt to secure.

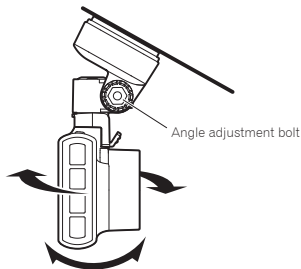
**Removing this product**

① While pressing the protruding part as shown in the figure below, ② remove the main unit.

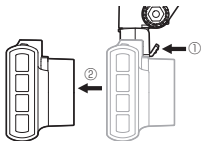

Install the Rear Camera

The top and bottom of the image can be set according to the mounting direction of the rear camera.

→ “This Product Settings” - “Configurable Features” - “Recording Setting” - “Install Position”

1 Clean the installation area of dirt and oils using the included cleaning cloth.

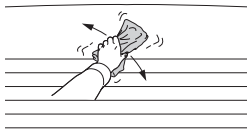

2 Install the rear camera.

① : Peel off the double-sided tape release paper from the rear camera.

② : Adjust the lens so that it faces outside the vehicle, and install at the specified position on the rear windscreen.

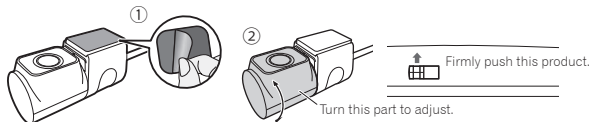

⚠ CAUTION

- Make sure that the surface of the rear windscreen is clean and dry, before attaching the rear camera.
- Use extreme care as the double-sided tape on the rear camera is extremely strong, and it will be difficult to reapply the tape once it has been applied.
- To ensure the installation strength of the adhesive tape, leave this product for 24 hours after application before using it.

Note

- A protective film is applied to the lens when the product is purchased. Peel off this film.

Connecting the Cables

- 1 Connect the cigarette lighter power cable and rear camera connection cable to the main unit.

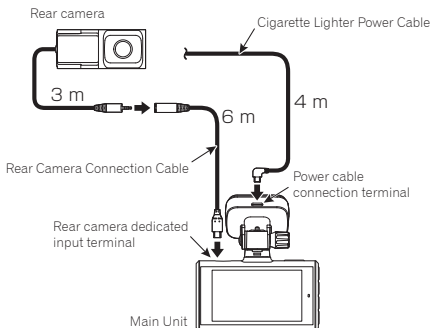

- 2 Route the cigarette lighter power cable and rear camera connection cable to the passenger seat side.

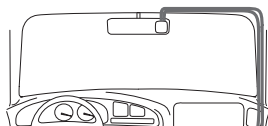

Rear camera wiring example

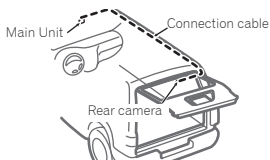

3 Connect the cigarette lighter power cable to the vehicle accessory socket.

Fully insert this into the vehicle accessory socket to make a good connection. (The location of the accessory socket will differ depending on the vehicle.)

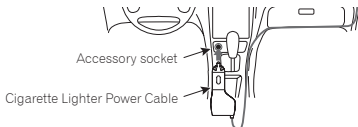

⚠ CAUTION

- The accessory socket will be extremely hot immediately after using the cigarette lighter. The tip of the cigarette lighter power cable may melt or short circuit if it is plugged in while the socket is hot. Wait for the socket to cool before plugging in the cigarette lighter power cable.

4 Turn the vehicle engine on to display the recording screen.

5 Adjust the angles of this product and of the rear camera lens so that video outside the vehicle is properly displayed.

To switch between camera video from the main unit and video from the rear camera, press the switch screen button.

→ ***“Function Buttons”***

Part Names

Main Unit

Top

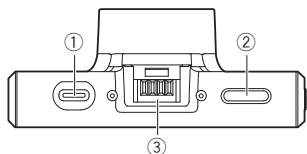

Bottom

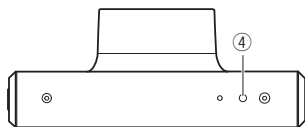

Front

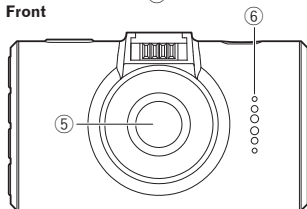

Back

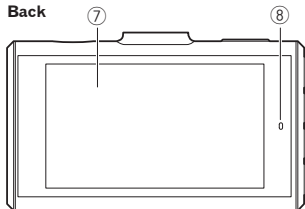

Left side

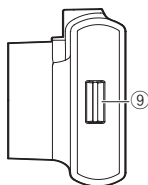

Right side

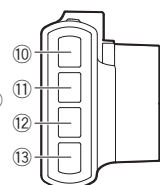

Mounting Bracket

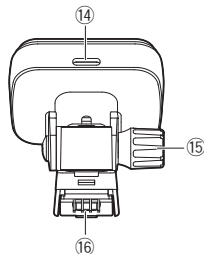

Rear camera

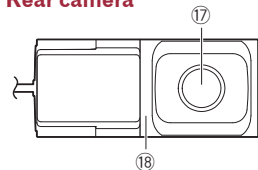

Main Unit

- ① **Rear camera dedicated input terminal**
Connects the rear camera connection cable.
- ② **Manual Record / Power Button**
Short press for manual recording.
Hold down to turn the power ON/OFF.
- ③ **Mounting Bracket Connection**
- ④ **Reset Button**
Press this button to reset this product. Push in using a narrow, blunt item.
- ⑤ **Lens**
- ⑥ **Speaker**
- ⑦ **LCD**
- ⑧ **System Indicator**
- ⑨ **microSD Card Slot**
- ⑩ **Menu / Function Button 1**
Stops video recording, and displays the main menu screen.
During menu screen display, this functions as Function Button 1.
- ⑪ **Microphone / Function Button 2**
Turns the microphone ON/OFF.
During menu screen display, this functions as Function Button 2.

- ⑫ **Switch Screen / Function Button 3**
This switches between the following each time it is pressed.
Front camera video → rear camera video
→ front camera video + rear camera video thumbnail → rear camera video + front camera video thumbnail → return to front camera video
During menu screen display, this functions as Function Button 3.
- ⑬ **Function Button 4**
During menu screen display, this functions as Function Button 4.
This does not operate in other than the menu screen.

Mounting Bracket

- ⑭ **Power cable connection terminal**
Connects the cigarette lighter power cable.
- ⑮ **Angle Adjustment Bolt**
Loosen to adjust the angle of this product.
- ⑯ **Product Insertion Part**

Rear Camera

- ⑰ **Lens**
- ⑱ **Angle Adjustment Jog Dial**
Turn to adjust the angle of the lens.

Function Buttons

During menu screen display, functions of the function buttons are linked to the icons displayed on the right side of the screen.

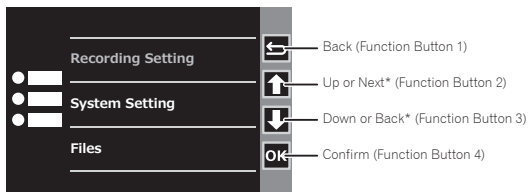

*When the sensitivity adjustment screen is displayed, these increase and decrease the sensitivity.

Inserting and Ejecting the microSD Card

Turn off the power to this product when inserting and removing the microSD card. → **“Manually Turning the Power On and Off”**

Inserting the microSD Card

Hold the top edge of the microSD card, position the microSD card so that the label is facing the frontside of this product, and slowly insert it into the microSD card slot until it clicks.

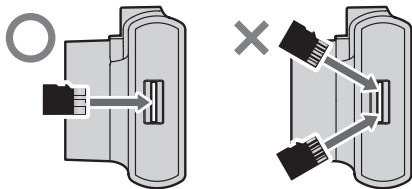

⚠ CAUTION

- Do not insert the microSD card at an angle. Doing so may cause damage.

Ejecting the microSD Card

Slowly push in the top edge of the microSD card until it clicks (①). The lock will be released. Pull out the microSD card (②).

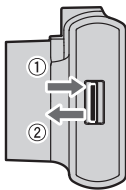

⚠ CAUTION

- Ensure care is taken when handling the microSD card, as it becomes hot after being written.

Backing Up Recorded Files

When the free space of the microSD card is low, files are deleted from the oldest file. We recommend that you back up any important files you want to keep with the following procedure.

Note

- Prepare a spare microSD card in advance.

1 Replace the microSD card.

Stop the vehicle in a safe location. Then turn off this product power, eject the microSD card, and replace it with a spare microSD card.

2 Copy or move the files to a PC.

Insert the microSD card into a PC, using the included SD card adapter if necessary.

Folder and File Structure

The structure of folders and files in a microSD card is as follows.

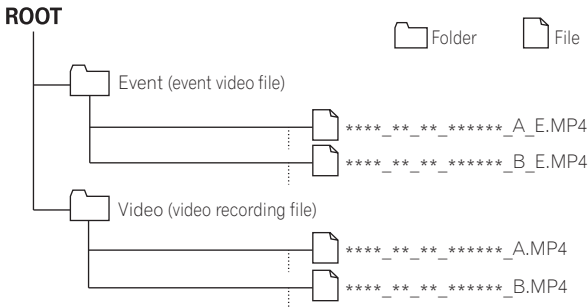

Note

- The year, month, day, hours, minutes, and seconds are automatically assigned at "****_**_**_*****".

Using this product

Before using this product, first stop the vehicle in a safe location and apply the handbrake.

This Product Power

This product starts when the vehicle's engine is turned on (ACC ON), and it automatically starts recording. (Video recording) → **“Using this product” - “Video Recording”**

⚠ CAUTION

- When the internal battery is empty or has insufficient charge (insufficient charging, power used up, etc.), then when starting the vehicle engine, the product may not start. If this product does not start, then wait approximately 3 minutes with the product charging, then remove and reinsert the cigarette lighter power cable from the cigarette lighter power socket to restart this product.

Manually Turning the Power On and Off

This product can be manually turned on and off.

On the recording screen, hold down the power button for at least 5 seconds to turn the power off. Never remove the microSD card while a file save processing message is displayed. Hold down the power button again for at least 5 seconds, and the power is turned on.

System Indicator Display

The operating status of this product is displayed with the system indicator.

System Indicator	Menu Displayed/ During Playback	Video Recording	Recording Event	Warning
Lit	—	○	—	—
A. Blinking (slow)	—	—	○	—
B. Blinking	—	—	—	○
Off	○	—	—	—

Blinks per second: A: 1; B: 2

How to View the Recording Screen

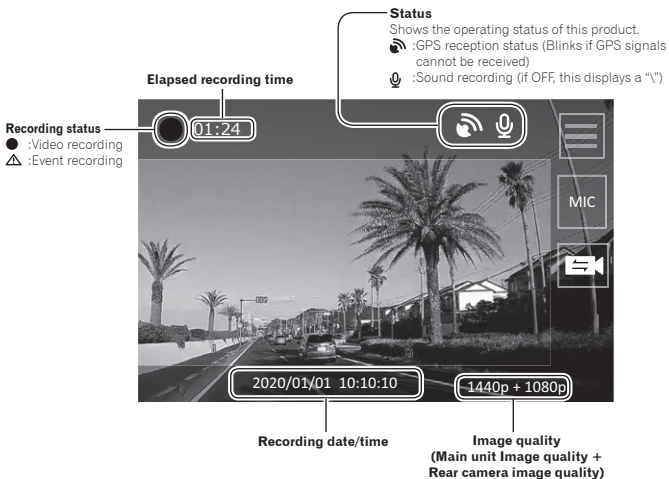

Video Recording

Recording automatically starts when this product is started. The recorded video is saved to the microSD card as one file of the set increment of time (default: 3 minutes), and when the microSD card runs out of free space, the files are overwritten starting from the oldest file.

Notes

- You can change the video recording time.
→ **"This product Settings" - "Configurable Features" - "Recording Setting" - "Video Resolution (Front)"**
- Video recording will stop under the following circumstances:
 - When the MENU screen is displayed
 - When the power supply is stopped
- The recording time may differ depending on the conditions.

Event Recording

Automatic Recording by Detecting Impacts (Event Recording)

The video recording file when an impact is detected by this product (the dash camera), such as an impact with another vehicle, is recorded as an event video file to the "Event" folder.

The number of event video files and recording times will differ depending on when an impact is detected.

Detection early in file

If an impact is detected within 20 seconds of the start of recording of a video recording file, then the file before that in which this impact was detected and the file for the 20 seconds after the impact is detected are recorded as two event video files.

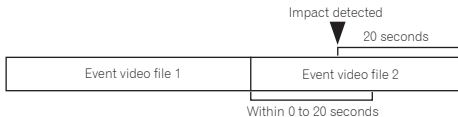

Detection late in file

If an impact is detected in the 19 seconds before the end of recording of a video recording file, then this file has its recording extended for 20 seconds after the impact is detected, and it is recorded as a single event video file.



Detection other than early or late in a file as above

The video from 20 seconds after the impact is detected, and the video recording file recorded from immediately before are recorded as a single event video file.

If the impact continues during the event recording period, an event file of up to 20 seconds will be added.

Manual Recording (Manual Event Recording)

If manual record button is pressed during video recording, then this is recorded as an event video file with the same specifications as an event recording.

Notes

- You can adjust the sensitivity for detecting impacts.
→ **“This product Settings” - “Configurable Features” - “Recording Setting” - “G-Sensor Sensitivity”**
- When impact was detected or manual recording was performed in the event recording mode, event recording is started again after event recording ends.
- The recording time may differ depending on the conditions.

Playing Recorded Files

You can play recorded video files.

1 Press the Menu button to open the main menu.

In each of the screens displayed from here on, the screen automatically returns to the recording screen if you do not perform any operation for approximately 30 seconds.

2 Press Function Button 2 or 3 to select [Files], and press Function Button 4.

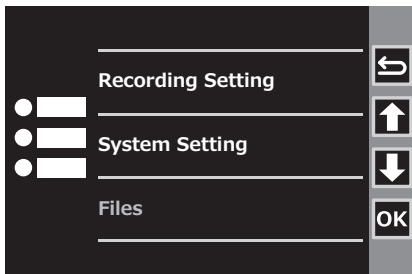

3 Press Function Button 2 or 3 to select [Video Recording] or [Event recording], and press Function Button 4.

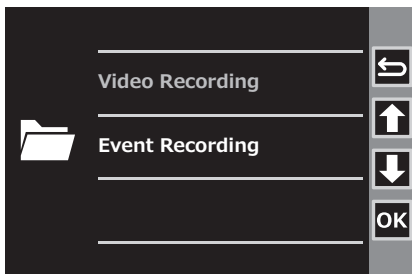

The thumbnails of files in the selected folder will be displayed.

4 Press Function Button 2 or 3 to select the file, and press Function Button 4.

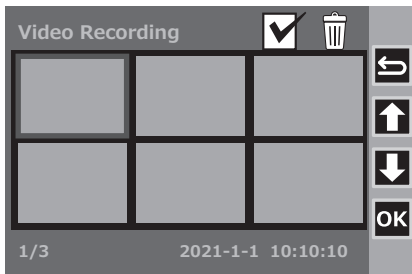

The selected file will play.

Notes

- Select [✓] and then press Function Button 4 to display [✓] for all files. In this state, select [🗑️] and then press Function Button 4 to display the confirmation screen to delete all files. Select [YES] to delete all files.
- Select [🗑️] and then press Function Button 4 to change the screen to the file selection screen. Select the files you want to delete (insert [✓]) and then select [🗑️] and press Function Button 4 again to display the file deletion confirmation screen. Select [YES] to delete only the selected files.

This Product Settings

Before using this product, first stop the vehicle in a safe location and apply the handbrake.

These settings configure this product. You can reset the settings to the default settings. You can also format the microSD card and check this product version information. Note that video recording will stop while the MENU screen is displayed.

1 Press the Menu button to open the main menu.

In each of the screens displayed from here on, the screen automatically returns to the recording screen if you do not perform any operation for approximately 30 seconds.

2 Press Function Buttons 2 or 3 to select [Recording Setting] or [System Setting], and press Function Button 4.

The following describes an example for when [Recording Setting] has been selected.

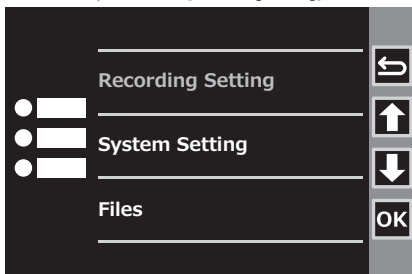

3 Press Function Button 2 or 3 to select the settings item, and press Function Button 4.

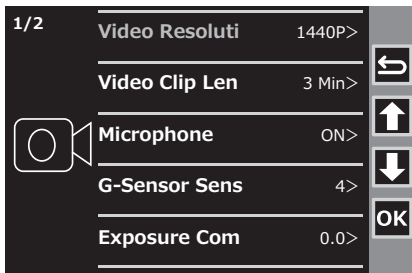

- 4 Press Function Button 2 or 3 to select the settings value, and press Function Button 4.

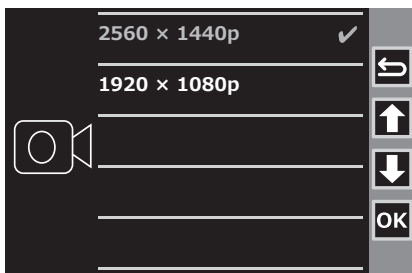

This completes setting, and you are returned to the previous screen.

Configurable Features

Recording Setting

Setting	Details	Default Settings
Video Resolution (Front)	Sets the image quality of video recording.	2560 x 1440p
Video Clip Length	Sets the recording time for one video recording video file in video recording.	3 Min
Microphone	Sets whether or not to record sound around this product during video recording.	OFF
G-Sensor Sensitivity	Sets the sensitivity for detecting vibration or impact. This can also be set to OFF.	4
Exposure Compensation (Front Camera)	Sets the exposure of video recording for the front camera.	0.0
Exposure Compensation (Rear Camera)	Sets the exposure of video recording for the rear camera.	0.0
Install Position	Sets the installation direction for the rear camera.	Pos. 1
LCD Display	Sets the image display for the rear camera.	FlipPic
Recording Format	Sets the recording format of video recording. *If set to H.265, playback may not be possible depending on the viewing software.	H.264

System Setting

Setting	Details	Default Settings
Language	Sets the language used to display the screen.	English
SD Card Format	All files on the microSD card can be deleted.	—
Date/Time	Sets the time manually.	—
GMT setting	Sets the time zone.	GMT+00:00

Setting	Details	Default Settings
Speed Unit	Sets the units used for speed display.	km/h
Monitor Display Setting	Sets the time that the products enter the sleep mode. When the menu is displayed, the product does not enter the sleep mode regardless of how this item is set.	3 Min
System Volume Setting	Sets beeps and playback volume. This can also be set to OFF.	Medium
Restore to Factory Mode	Settings can be reset to the default settings (initialized). When initialization is completed, this product will automatically restart.	—
OSS	Allows you to check the information on licenses used in this product.	—
System Information	Allows you to check the product model number and firmware version information of this product.	—

Guide to Recording Time

The following table provides estimates of the video recording times possible with different SD card capacities. The actual values will depend on various factors, such as the microSD card being used, subject being recorded, and recording conditions.

Guide to Recording Time with a 16 GB microSD Card

Compression Method	Resolution	Video Recording	Event Recording
H.264	2560 × 1440P	Approx. 1 hour	Approx. 25 minutes
	1920 × 1080P	Approx. 1 hour 20 minutes	Approx. 34 minutes
H.265	2560 × 1440P	Approx. 1 hour 10 minutes	Approx. 30 minutes
	1920 × 1080P	Approx. 1 hour 30 minutes	Approx. 38 minutes

Guide to Recording Time with a 128 GB microSD Card

Compression Method	Resolution	Video Recording	Event Recording
H.264	2560 × 1440P	Approx. 8 hour	Approx. 3 hour 20 minutes
	1920 × 1080P	Approx. 10 hour 40 minutes	Approx. 4 hour 30 minutes
H.265	2560 × 1440P	Approx. 9 hour 20 minutes	Approx. 4 hour
	1920 × 1080P	Approx. 12 hour	Approx. 5 hour 10 minutes

Note

- The recording times are estimates. The actual recording times will depend on the scenery being recorded.

Troubleshooting

Check the following information before sending the product in for repairs.

Symptom	Cause	Action
An error occurred during the display and operation of this product.	The microcomputer in this product is malfunctioning.	Press the reset button. → “Part Names”
A file that should have been saved cannot be found.	If there is insufficient space in the storage areas of the microSD card, the files will be overwritten in order from the oldest files.	We recommend that you back up any important files you want to keep. → “Backing Up Recorded Files”
An accident occurred during driving, but a video file wasn't recorded.	The sensitivity of impact detection may not be appropriate.	Adjust the sensitivity of the sensors to use for detection. → “This Product Settings” - “Configurable Features” - “Recording Setting” - “G-Sensor Sensitivity”
There's no sound when I play a video file.	The sound recording setting may be OFF.	Check the sound recording setting again. → “This Product Settings” - “Configurable Features” - “Recording Setting” - “Microphone”

Specifications

Recording Medium	microSDHC/microSDXC card, Class 10 (16 GB to 128 GB)
Imaging Element	Main Unit: Approx. 3.7 million pixels (on-board high-sensitivity CMOS sensor) Rear camera: Approx. 2 million pixels (on-board high-sensitivity CMOS sensor)
Recording Angles	Main Unit: 112° horizontal, 60° vertical, 135° diagonal Rear camera: 105° horizontal, 55° vertical, 128° diagonal
F-Number	Main Unit: F1.4 Rear camera: F1.8
Recording mode	Main Unit: 2560 × 1440P/1920 × 1080P Rear camera: 1920 × 1080P
GPS	Built-in
G-Sensor	3-axis G-sensor (level can be set in 7 steps)
Recording Methods	Video recording/event recording/manual event recording
Video File Structure	1 min / 3 min
Display	3.0-inch LCD
Sound Recording	Can be set to ON or OFF
Frame Rate	27.0 fps
Compression Method	MP4 (H.264 / H.265)*
Power Supply Voltage	Main Unit: DC 5 V (12 V / 24 V cigarette lighter power cable included)
Power Consumption	4.2 W
Operating Temperature	-10 °C to +60 °C
Dimensions (W × H × D)	Main Unit: 90.5 mm × 101.9 mm × 36 mm (width × height × depth) Rear camera: 58.9 mm × 25.1 mm × 31.5 mm (width × height × depth)
Weight	Main Unit: 125 g (Including bracket) Rear camera: 250 g (Including cable)
Allowable Installation Angle	Main Unit: 20° to 75° Rear camera: 0° to 90°

*: If you select MP4 (H.265), you can play it with MP4 (H.265) compatible software (VLC player, etc.).
If you want to play with Windows Media™ Player, you need to install the HEVC codec.

GPS

- GPS (Global Positioning System) is a system that measures your current position by receiving position measurement radio signals from GPS satellites.
- The GPS satellite signals cannot pass through solid matter (except glass). The signals from GPS satellites may be blocked when this product is in the following locations:
 - Inside tunnels and parking structures
 - On the bottom level of a two-level highway
 - Around concentrations of skyscrapers
 - In dense forests

| Trademarks & Copyrights

- microSDHC Logo is a trademark of SD-3C, LLC.



- microSDXC Logo is a trademark of SD-3C, LLC.



- Windows Media is either a registered trademark or trademark of Microsoft Corporation in the United States and/or other countries.

<https://www.pioneer-car.eu/eur/>

Visit www.pioneer-car.eu/uk/ (or www.pioneer-car.eu/eur/) to register your product.

PIONEER CORPORATION

28-8, Honkomagome 2-Chome, Bunkyo-ku,
Tokyo 113-0021, Japan

PIONEER EUROPE NV

Haven 1087, Keetberglaan 1, B-9120 Melsele, Belgium/Belgique
TEL: +32 (0)3 570 05 11
Salamanca, Wellington Street, Slough, Berkshire, SL1 1YP, UK
TEL: +44 (0)208 836 3500